

Operating Instructions
Ultra-Low Temperature Freezer
MDF-C2156VAN
MDF-C2156VANC

MDF-C2156VAN
MDF- Series
C2156VANC



Please read these instructions carefully before using this product, and save this operating instructions for future use.

See page 42 for all Model numbers.

CONTENTS

INTRODUCTION	P. 2
PRECAUTIONS FOR SAFE OPERATION	P. 3
ENVIRONMENTAL CONDITIONS	P. 7
FREEZER COMPONENTS	P. 8
Control panel	P. 11
INSTALLATION SITE	P. 12
INSTALLATION	P. 13
START-UP OF UNIT	P. 14
Operation after power failure	P. 14
BASIC SCREEN OF CONTROL PANEL	P. 15
FUNCTION OF CONTROL PANEL	P. 15
RUNNING OPERATION (MENU/Set)	P. 16
Key lock function	P. 17
Key lock release function	P. 17
VARIOUS SETTING (MENU/Log)	P. 18
Display of log (Log)	P. 18
VARIOUS SETTING (MENU/Tools)	P. 20
Initialization (Tools/ Default Setting)	P. 20
Setting of date, time, log interval (Tools/Date Time)	P. 21
Setting of key lock password (Tools/Key lock PW Setting)	P. 22
ALALRM BUZZER	P. 22
MONITOR OF FREEZER STATUS	P. 23
ALARMS & SAFETY FUNCTIONS	P. 23
REMOTE ALARM TERMINAL	P. 25
BACKUP COOLING KIT	P. 25
ROUTINE MAINTENANCE	P. 27
Cleaning of cabinet	P. 27
Cleaning of condenser filter	P. 27
Defrosting of inside wall	P. 28
REPLACEMENT OF BATTERY	P. 29
TROUBLESHOOTING	P. 30
DISPOSAL OF UNIT	P. 31
Recycle of battery	P. 31
TEMPERATURE RECORDER (OPTION)	P. 36
MOUNTING OF INTERFACE BOARD (OPTION)	P. 40
SPECIFICATIONS	P. 41
PERFORMANCE	P. 42
SAFETY CHECK SHEET	P. 43

INTRODUCTION

■ Read this operating instructions carefully before using the appliance and follow the instructions for safety operation.

■ Our company never guarantee any safety if the appliance is used for any objects other than intended use or used by any procedures other than those mentioned in this operating instructions.

■ Keep this operating instructions in an adequate place to refer to it as necessary.

■ The contents of the operating instructions will be subjected to change without notice due to the improvement of performance or functions.

■ Contact our sales representative or agent if any page of the operating instructions is lost or page order is incorrect.

■ Contact our sales representative or agent if any point in this operating instructions is unclear or if there are any inaccuracies.

■ No part of this operating instructions may be reproduced in any form without the expressed written permission of our company.

CAUTION

Our company guarantees the product under certain warranty conditions. Our company in no way shall be responsible for any loss of content or damage of content.

Microsoft, Windows, Windows 7, Windows Vista, Windows XP and Windows 2000 are registered trademarks in the United States of Microsoft Corporation and various other countries.

PRECAUTIONS FOR SAFE OPERATION

It is imperative that the user complies with this operating instruction as it contains important safety advice.

Items and procedures are described so that you can use this unit correctly and safely. If the precautions advised are followed, this will prevent possible injury to the user and any other person.

Precautions are illustrated in the following way:





Failure to observe WARNING signs could result in a hazard to personnel possibly resulting in serious injury or death.



Failure to observe CAUTION signs could result in injury to personnel and damage to the unit and associated property.

Symbol shows;

this  symbol means caution.

this  symbol means an action is prohibited.

this  symbol means an instruction must be followed.

Be sure to keep this operating instruction in a place accessible to users of this unit.

< Label on the unit >



This mark is labeled on the cover in which the electrical components of high voltage are enclosed to prevent the electric shock.















The cover should be removed by a qualified engineer or a service personnel only.

WARNING

As with any equipment that uses N2 gas, there is a likelihood of oxygen depletion in the vicinity of the equipment. It is important that you assess the work site to ensure there is suitable and sufficient ventilation. If restricted ventilation is suspected, then other methods of ensuring a safe environment must be considered. These may include atmosphere monitoring and warning devices.















PRECAUTIONS FOR SAFE OPERATION

WARNING

-  Do not use the unit outdoors. Current leakage or electric shock may result if the unit is exposed to rain water.
-  Only qualified engineers or service personnel should install the unit. The installation by unqualified personnel may cause electric shock or fire.
-  Install the unit on a sturdy floor and take an adequate precaution to prevent the unit from turning over. If the floor is not strong enough or the installation site is not adequate, this may result in injury from the unit falling or tipping over.
-  Never install the unit in a humid place or a place where it is likely to be splashed by water. Deterioration of the insulation may result which could cause current leakage or electric shock.
-  Never install the unit in a flammable or volatile location. This may cause explosion or fire.
-  Never install the unit where acid or corrosive gases are present as current leakage or electric shock may result due to corrosion.
-  Always ground (earth) the unit to prevent electric shock. If the power supply outlet is not grounded, it will be necessary to install a ground by qualified engineers.
-  Never ground the unit through a gas pipe, water main, telephone line or lightning rod. Such grounding may cause electric shock in the case of an incomplete circuit.
-  Connect the unit to a power source as indicated on the rating label attached to the unit. Use of any other voltage or frequency other than that on the rating label may cause fire or electric shock.
-  Never store volatile or flammable substances in this unit if the cylinder cannot be sealed. These may cause explosion or fire.
-  Do not insert metal objects such as a pin or a wire into any vent, gap or any outlet on the unit. This may cause electric shock or injury by accidental contact with moving parts.
-  Use this unit in safe area when treating the poison, harmful or radiate articles. Improper use may cause bad effect on your health or environment.
-  Turn off the power switch (if provided) and disconnect the power supply to the unit prior to any repair or maintenance of the unit in order to prevent electric shock or injury.
-  Do not touch any electrical parts (such as power supply plug) or operate switches with a wet hand. This may cause electric shock.







PRECAUTIONS FOR SAFE OPERATION

WARNING

-  Ensure you do not inhale or consume medication or aerosols from around the unit at the time of maintenance. These may be harmful to your health.
-  Never plug a power cord directly into the unit.
-  Never put cylinders with liquid on the unit as this may cause electric shock or short circuit when the liquid is spilled.
-  Never bind, process, or step on the power supply cord, or never damage or break the power supply plug.
A broken supply cord or plug may cause fire or electric shock.
-  Do not use the supply cord if its plug is loose. Such supply cord may cause fire or electric shock.
-  Never disassemble, repair, or modify the unit yourself. Any such work carried out by an unauthorized person may result in fire, or electric shock or injury due to a malfunction.
-  Disconnect the power supply plug if there is something wrong with the unit. Continued abnormal operation may cause electric shock or fire.
-  When removing the plug from the power supply outlet, grip the power supply plug, not the cord. Pulling the cord may result in electric shock or fire by short circuit.
-  Disconnect the power supply plug before moving the unit. Take care not to damage the power cord. A damaged cord may cause electric shock or fire.
-  Disconnect the power plug when the unit is not used for long periods. Keeping the connection may cause electric shock, current leakage, or fire due to the deterioration of insulation.
-  If the unit is to be stored unused in an unsupervised area for an extended period, ensure that children do not have access and that doors cannot be closed completely.
-  The disposal of the unit should be accomplished by appropriate personnel. Remove doors to prevent accidents such as suffocation.
-  Do not put the packing plastic bag within reach of children as suffocation may result.
- 

PRECAUTIONS FOR SAFE OPERATION

CAUTION

-  Use a dedicated power source (a dedicated circuit with a breaker) as indicated on the rating label attached to the unit. A branched circuit may cause fire resulting from abnormal heating.
- Connect the power supply plug to the power source firmly after removing the dust on the plug.
-  A dusty plug or improper insertion may cause a heat or ignition.
- Never store corrosive substances such as acid or alkali in this unit if the cylinder cannot be sealed.
-  These may cause corrosion of inner components or electric parts.
- Check the setting when starting up of operation after power failure or turning off of power switch. The stored items may be damaged due to the change of setting.
-  Be careful not to tip over the unit during movement to prevent damage or injury.
-  Prepare a safety check sheet when you request any repair or maintenance for the safety of service
-  personnel.

ENVIRONMENTAL CONDITIONS

This equipment is designed to be safe at least under the following conditions (based on the IEC 61010-1):

■ Indoor use;

■ Altitude up to 2000 m;

■ Ambient temperature 5°C to 40°C;

■ Maximum relative humidity 80% for temperature up to 31°C decreasing linearly to 50% relative humidity at 40°C;

■ Mains supply voltage fluctuations up to $\pm 10\%$ of the nominal voltage;

■ Transient overvoltages up to the levels of OVERVOLTAGE CATEGORY II;

■ Temporary OVERVOLTAGES occurring on the mains supply;

■ Applicable pollution degree of the intended environment (POLLUTION DEGREE 2 in most cases).

FREEZER COMPONENTS

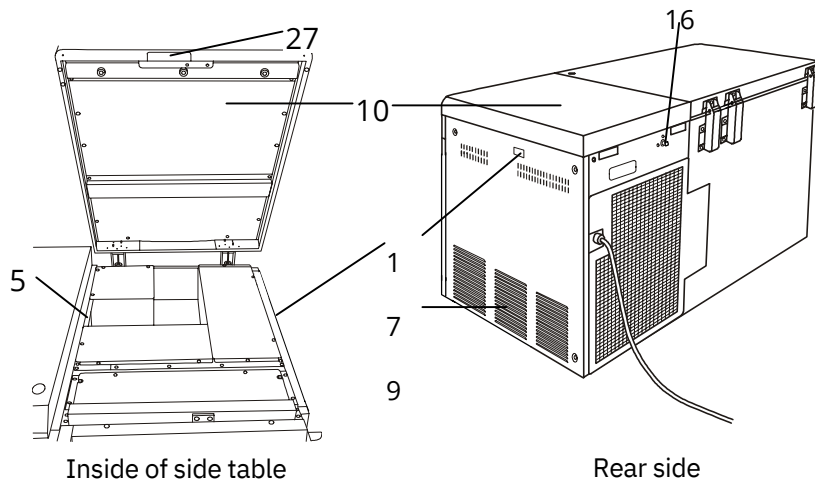
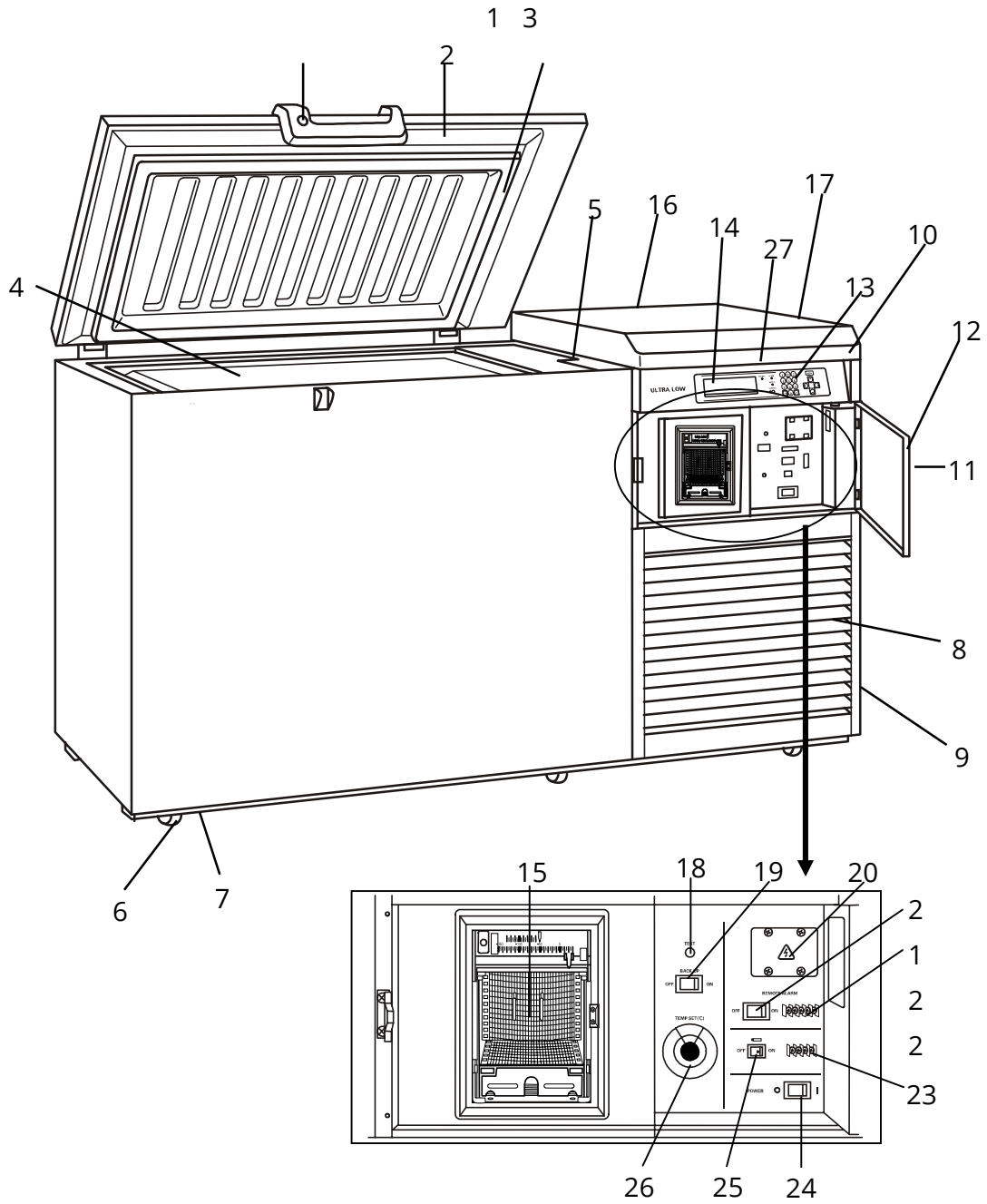

FREEZER COMPONENTS

1. Lock: Turn clockwise to 180 with a key and the outer door is securely locked.
2. Door: Hinged type. The door can be opened in any angle on the way to full open.
3. Magnetic door gasket: Seals the door and prevents leakage of cold air.
4. Inner lid: Serves as a means of reducing cold air leakage when the door is open.
5. Access port: Serves a means of leading the measuring cable from the freezing room to the outside.
6. Caster: 6 casters are provided. They make the moving of the unit easier.
7. Leveling foot: Serves to adjust the height and to settle the frame.
8. Grille: Acts as an inlet for air to cool the motor. Be careful not to block this. By pulling down this grille, you can clean a clogged condenser filter. See page 27 for the details.
9. Exhaust air vent: Be careful not to block this.
10. Side table: A door can be opened. There are an access port and a remote alarm cable output port in the inside.
11. panel door Lock: To lock the control cover to avoid the setting by accidental contact.
12. Panel door: There is a controller such as a power switch inside the panel door.
13. Control panel: Refer to page 11.
14. Digital temperature indicator: This indicator shows the present temperature or setting temperature.
15. Temperature recorder (OPTION): Refer to page 38.
16. Backup cooling kit joint: It is positioned at rear of the unit. Serves to connect with the pipelines from the cylinder (liquid N₂) at the top right of the rear frame. Refer to page 26 “Backup cooling kit”
17. Remote alarm cable output port
18. Backup test switch (TEST): Examine the functions of the backup cooling kit. This switch allows liquid N₂ to spout under any circumstances. Handle it according to page 26 “Backup cooling kit”.
19. Backup switch (BACK UP): Switch on for operation of the backup cooling kit and switch off for stopping. Handle this switch according to page 26 “Backup cooling kit”.

Refer to “Mounting of interface board (OPTION)” on page 40 for usage.

20. Communication box cover:

FREEZER COMPONENTS

21. Remote alarm switch (REMOTE ALARM): This switch is for remote alarm. In case of operating remote alarm, turn on the switch.

22. Remote alarm terminal (MAX DC30V 2A)

23. Analog output terminal (ANALOG VOLTAGE)

24. Power supply switch (POWER):

25. Battery switch: It is the switch of the battery for the power failure alarm. Turn it on usually. Turn it off when you do not drive for a long time. (More than 1 month)

26. Temperature control knob (TEMP. SET(oC)): It is the knob which adjusts operation temperature of the backup cooling kit device.

27. Side table handle: There is a lever at the center of the front. when it is pulled to the front, the side table is open.

FREEZER COMPONENTS

Control panel

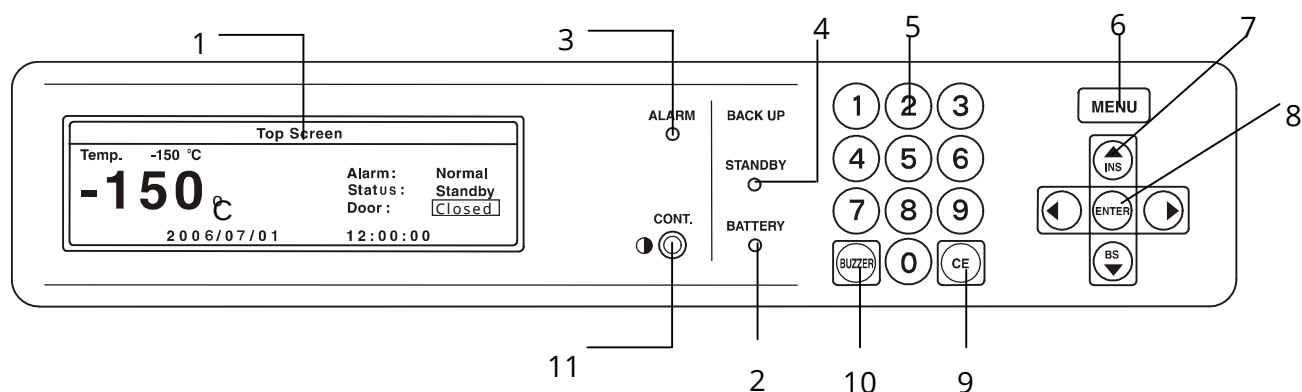

1. LCD panel

2. Battery check lamp (BATTERY):

This lamp lights when the battery capacity decreases at the power failure. Batteries are expendable supplies. Replace a battery with every three years. For the replacement, consult our sales representative or agent.

3. Alarm lamp (ALARM): This lamp flashes when the unit is in alarm condition.

4. Backup lamp (STANDBY): This lamp lights when the backup switch is on. (This doesn't show backup cooling kit is activated.)

5. Figure input key: User for operation setting.

6. Menu button (MENU): To open the menu window.

7. Shift key (Upward, downward, rightward, leftward): To move the cursor on the LCD panel.

8. Enter key (ENTER): To determine the selection of menu.

9. Clear key (CE): To clear the input value during setting.

10. Alarm buzzer stop key (BUZZER):

- Buzzer stop key : Refer to page 22 for the details.

- Alarm test : Refer to page 15 for the details.

- Chamber temperature display key: The chamber temperature is displayed by pressing this key during power failure..

To adjust the contrast of LCD panel.

11. LCD contrast adjusting knob (CONT.):

INSTALLATION SITE

To operate this unit properly and to obtain maximum performance, install the unit in a location with the following conditions:

 location not subjected to direct sunlight

Do not install the unit under direct sunlight. Installation in a location subjected to direct sunlight cannot obtain the intended performance.

 location with adequate ventilation

Leave at least 10 cm around the unit for ventilation. Poor ventilation will result in a reduction of the performance and consequently the failure.

 location away from heat generating sources

Avoid installing the unit near heat-emitting appliances such as a heater or a boiler etc. Heat can decrease the intended performance of the unit.

 location with little temperature change

Install the unit under stable ambient temperature. The allowable ambient temperature is between -5 and +35°C.

 location with a sturdy and level floor

Always install the unit on a sturdy and level floor. The uneven floor or tilted installation may cause failure or injury. Install the unit in stable condition to avoid the vibration or noise. Unstable condition may cause vibration or noise.

WARNING

Install the unit on a sturdy floor. If the floor is not strong enough or the installation site is not adequate, this may result in injury from the unit falling or tipping over. Select a level and sturdy floor for installation. This precaution will prevent the unit from tipping. Improper installation may result in water spillage or injury from the unit tipping over.

 location not prone to high humidity

Install the unit in the ambient of 80% R.H. or less humidity. Installation under high humidity may cause current leakage or electric shock.

WARNING

Current leakage or electric shock may result if the unit is exposed to rain water.

Never install the unit in a humid place or a place where it is likely to be splashed by water. Deterioration of the insulation may result which could cause current leakage or electric shock.

 location without flammable or corrosive gas

Never install the unit in a flammable or volatile location. This may cause explosion or fire or may result in the current leakage or electric shock by the corrosion of the electrical components.

 location without the possibility of anything fall

Avoid installing the unit in the location where anything can fall down onto the unit. This may cause the breakdown or failure of the unit.

INSTALLATION

1. Removing the packaging materials and tapes

Remove all transportation packaging materials and tapes. Open the doors and ventilate the unit. If the outside panels are dirty, clean them with a diluted neutral dishwashing detergent. (Undiluted detergent can damage the plastic components. For the dilution, refer to the instruction of the detergent.) After the cleaning with the diluted detergent, always wipe it off with a wet cloth. Then wipe off the panels with a dry cloth.

Note:

Remove the cable tie banding the power supply cord. Prolonged banding may cause the corrosion of the cord coating.

2. Adjusting the leveling foot

Extend the leveling feet by rotating them counterclockwise to contact them to the floor. Ensure the unit is level.

Leveling foot

3. Fixing the unit

Two fixtures are attached to the rear of the frame.

Fix the frame to the wall with these fixtures and rope or chain.

4. Ground (earth)

The ground (earth) is for preventing the electric shock in the case of the electrical insulation is somehow degraded. Always ground the unit at the time of installation.

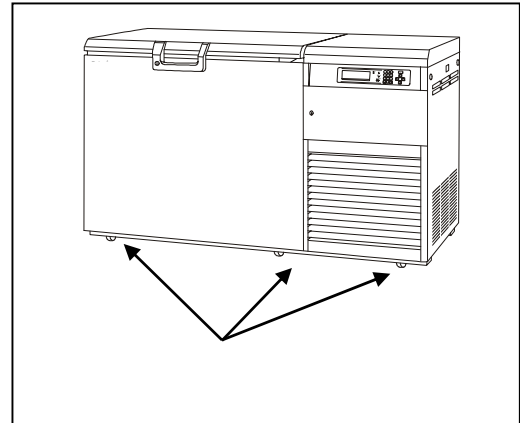

WARNING

Use a power supply outlet with ground (earth) to prevent electric shock. If the power supply outlet is not grounded, it is necessary to install a ground by qualified engineers.

Never ground the unit through a gas pipe, water main, telephone line or lightning rod. Such grounding may cause electric shock in the case of an incomplete circuit.

START-UP OF UNIT

Follow the procedures for the initial and consequent operations of the unit.

1. Confirm that all switches kinds (power supply switch, battery switch, remote alarm switch and backup cooling kit switch) are off.
2. Set liquid N2 cylinder.
3. Put the inner lid, close the door, and connect a power cord to the power supply.
4. Turn on the power supply switch. The chamber temperature is indicated.
5. Set up the temperature with the temperature control knob when using a backup cooling kit.
6. Turn on the battery switch, remote alarm switch and backup switch.
7. Push the alarm buzzer stop key (BUZZER) for about 5 seconds, and confirm the flashing of the alarm lamp and a buzzer sound. When it is pushed again, an alarm test movement is finished.
8. Push the backup test switch, and confirm that liquid N2 flows into the freezer.
9. Turn off a remote alarm switch and a backup switch when temperature of the sample is high. Then, turn on these switches under the condition that a sample is refrigerated again.

Operation after power failure

The set value is memorized by nonvolatile memory. Accordingly, the chamber resumes the operation with setting before power failure. During the power failure, the clock function is operating.

- Change a setting as necessary because the freezer resumes with -150oC setting if the battery is discharged.

BASIC SCREEN OF CONTROL PANEL

When the power supply switch is turned on, the basic screen of the control panel is indicated. The numerical value after "Temp" shows set temperature, and a big number under that shows present chamber temperature. The bottom shows a present date and time.

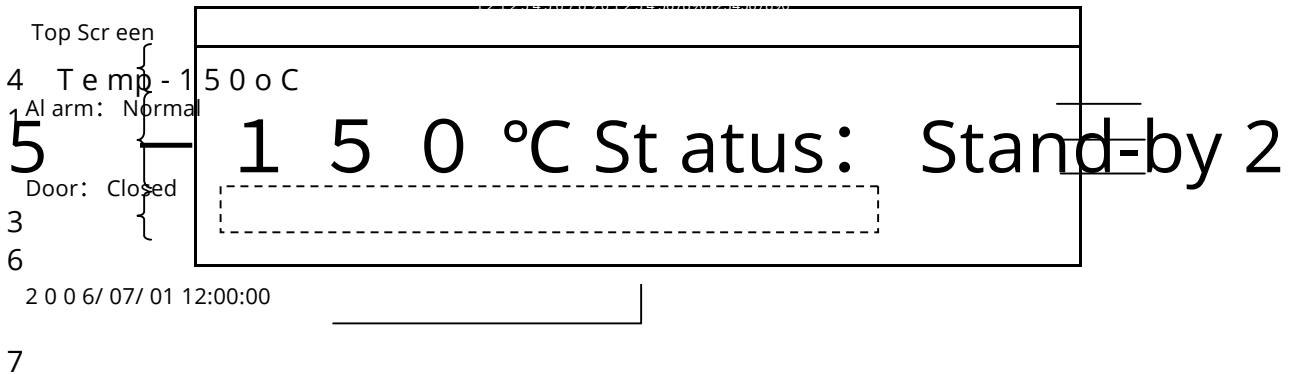

1. Display of alarm (Alarm) : An “Alarm” is indicated alternately in the reversal/non-reversal character during the alarm operation. Warning is indicated alternately in the reversal/non-reversal character at the time of warning. “Normal” is usually indicated. The complementary message is indicated in the message column.
 - “Test” is indicated alternately at the alarm test by the reversal/non-reversal.
2. Display of status (Status): The message of the indication (Status) of the status number and the complement is indicated in the message column. An error message is indicated at the time of warning. Refer to page 23 for the details. “Stand-by” is usually indicated.
3. Display of door status (Door): “Door” is highlighted when the door is open. When a door is close, it is indicated with "Closed". (usual character)
4. Display of setting (Temp) : Set value of chamber temperature is displayed.
5. Display of current value: Current value of chamber temperature is displayed.
6. Message indication: Various messages are indicated. Refer to page 23 for the details.
7. Display of date and time: The current date and time are displayed.

FUNCTION OF CONTROL PANEL

The following functions are available through control panel:

1. Setting of standby operation: To set a running condition at the start-up. (refer to page 16)
2. Setting of log cycle and sending to PC: To set a log cycle of running data and to send a running log to PC. (page 19)
3. Setting of date and time: To set the date and time shown on the basic screen. (page 21)
4. Setting/display of alarm: High limit (or low limit) temperature setting (page 16) . Power failure alarm (page 23) and filter alarm (page 23) are indicated.
5. Default setting: To set the default for LCD panel and communication (DAQ) speed etc. (page 20)
6. Alarm test: The test of alarm buzzer, alarm lamp and remote alarm is effective by pressing the alarm buzzer stop key (BUZZER) for about five seconds during normal operation. Pressing the key again finishes the alarm test.

RUNNING OPERATION (MENU/Set)

This product is operated with set temperature at the time of start-up.

1. With the basic screen displayed, press the menu button (MENU) to show the menu window. Select "Set", and press the enter key (ENTER).

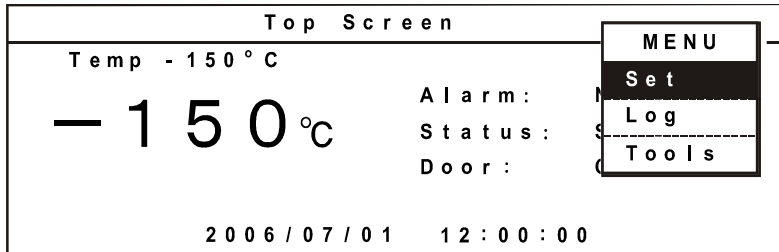

2. A temperature setup screen (Temp. Setting) is indicated. Set up each parameter.

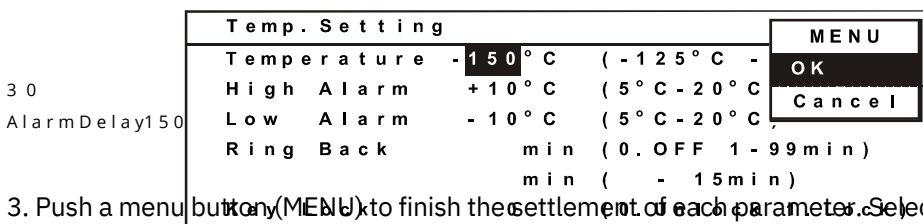

3. Push a menu button (MENU) to finish the settlement of each parameter. Select OK on the menu window, and push the enter key (ENTER). The setting is memorized.

Each parameter setting range:

●Temperature : amber temperature. Temperature settable range : -125~-152C (The factory setting is -150oC.)

●High Alarm: It is the set point of the high temperature alarm. Temperature settable range: Chamber temperature +50o~+20C (The factory setting is +10C)

●Low Alarm: It is the set point of the low temperature alarm. Temperature settable range: Chamber temperature -5-20oC The factory seo~ (tting is -10C)

●Ring Back: This is the duration between the stop of alarm buzzer and next start of alarm buzzer. The settable range is between 1 minute and 99 minutes. The alarm buzzer is not back again when the setting is 0. (The factory setting is 15 minutes)

●Alarm Delay: The settable range of the alarm delay time is between 0 and 15 minutes. With 0 setting, the alarm buzzer activates immediately without delay. (The factory setting is 15 minutes.)

●Key Lock: When "Lock" is chosen, a set point cannot be changed. The input of the password is necessary at the time of release.

Note : An alarm buzzer operates 15 minutes after it became a state of alarm. When a door is open, it is indicated on the basic screen (Door) by "Open" and the reversal.

RUNNING OPERATION (MENU/Set)

Key lock function

1. On the temperature setting screen (Temp. screen), input 1 in the “Key Lock” field. Press the enter key (ENTER) and the buzzer sounds shortly and the key lock is effective.

Temp. Setting		MENU
Temperature	- 150 °C (- 125 °C -	OK
High Alarm	+ 10 °C (5 °C - 20 °C	Cancel
Low Alarm	- 10 °C (5 °C - 20 °C	
Ring Back	15 min (0. OFF 1 - 99 min)	
Door Delay	2 min (1 - 15 min)	
Key Lock	0 (0. Unlock 1. Lock)	

2. “Key Lock” is indicated on the top line. The change of setting is impossible.

Temp. Setting		Key Lock	MENU
Temperature	- 150 °C (- 125 °C -		OK
High Alarm	+ 10 °C (5 °C - 20 °C		Cancel
Low Alarm	- 10 °C (5 °C - 20 °C		
Ring Back	15 min (0. OFF 1 - 99 min)		
Door Delay	2 min (1 - 15 min)		
Key Lock	1 (0. Unlock 1. Lock)		

Key lock release function

1. On the temperature setting screen (Temp. Setting), input 0 in the “Key Lock” field, and press the enter key (ENTER).

Temp. Setting		Key Lock	MENU
Temperature	- 150 °C (- 125 °C -		OK
High Alarm	+ 10 °C (5 °C - 20 °C		Cancel
Low Alarm	- 10 °C (5 °C - 20 °C		
Ring Back	15 min (0. OFF 1 - 99 min)		
Door Delay	2 min (1 - 15 min)		
Key Lock	1 (0. Unlock 1. Lock)		

2. The cursor is moved to the password column (Password). Input 4-digit password and press the enter key (ENTER). The buzzer sounds shortly and the key lock is released. The “Key Lock” indication of the temperature setting screen (Temp. Setting) disappears.

Temp. Setting		ocLk o c l
Temperature - 150 o C (- 125oC -11552oC)		
High Alarm + 10 o C (5 oC-20oC)		
Low Alarm - 10 o C (5 oC-20oC)		
Ring Back 15 min (0. OFF 1-99min)		
Door Delay 2 min (1 -15min)		
		Key Lock 0
		ord

Note :

The buzzer sounds if a password is wrong. Again, input a password. A user should manage a password with all of the members. Factory setting is 0000. Refer to page 22.

VARIOUS SETTING (MENU/Log)

Display of log (Log)

1. On the basic screen, press the menu button (MENU) to show the menu window. Select log, and press the enter key (ENTER).

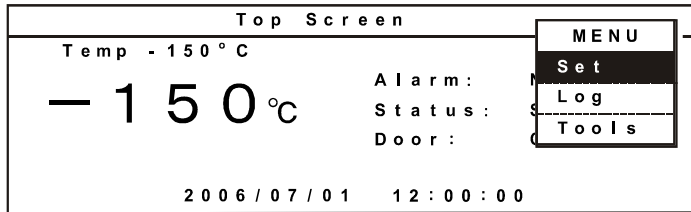

2. When accumulated data (for one day) are transmitted to the PC: Press the menu (MENU), select “PC 1D” and press the enter key (ENTER). When all accumulated data are transmitted to the PC: Press the menu button(MENU), select “PC ALL” and press the enter key (ENTER). All accumulated records are indicated with a dot. A graph display (PC 1D) is indicated. (1 page 24-hour indication)

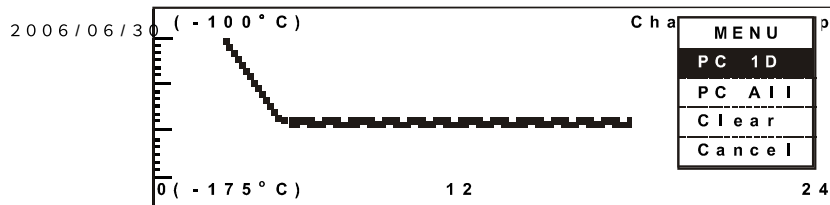

3. Data transmitting screen is indicated. Specify a transfer, a capture of the textbook and a preservation file name by the operation on the PC side hyper-terminal. Specify the extension of the preservation file name with txt or csv. Press the menu button (MENU), select “start” and press the enter key (ENTER). The transmission is started. The transmission is finished when a finished message comes out.

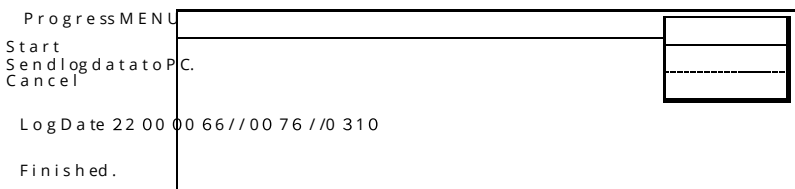

- Each parameter setting range:
- Temperature :50-25 oC-25-100 oC-100-175 oC
 - Temperature range is changed with ↑, ↓, ~, ~, ~C
 - It is moved with ← and → to date. (←: Past date, →: New date)
 - A data interval is 2 minutes from 30 minutes. (The factory setting is 15 min..)
- With 15 minutes interval, the recording for about 5 weeks is available. With 6 minutes interval, the recording for about 2 weeks is possible.
- Pop-up screen is indicated when “PC 1D” is selected. Log data on date (for 1 day) indicated.
 - Pop-up screen is indicated when “PC ALL” is selected and all memory log data are transmitted.
 - Pop-up screen is indicated when the clear key (CE) is pushed. All log data are erased when OK is selected by pop-up MENU.

Note :

- When log data are full, it is erased automatically in order from the old data.
- The communication cable for the interface board MTR-480 of the option and 9 pin Dsub cross type for RS232C is necessary for the data transmission to the PC. Refer to page 40 for the details.

VARIOUS SETTING (MENU/Log)

The operation of the hyper-terminal on the PC side

1. Transmission starts when a transfer, a capture of the text and a preservation file name are specified and MENU/Start is selected.

The transmission is finished, with "Finished" indication.

Setup of communication: Log data receipt on the PC side (In case of Windows 2000 and XP)

1. Start a program-accessories-communication-hyper-terminal from the starting button. The registration of the starting menu is to start in the following method, C : Start from ¥Program Files¥ Windows NT¥hypertrm.exe.

2. Set up the following through the hyper-terminal screen.

- New connection Name (Example) Panasonic
- Setup of the connection Connection port COM1
- Properties of COM1 Setup of the port
- Bit/sec.: 9600 Data bit: 8 Parity: No Stop bit: 1 Flow control: Xon/Xoff

(When a log transmitting screen is opened, terms of communication on the MDF side are set on the above condition automatically.)

3. The communication cable for the interface board MTR-480 of the option and 9 pin Dsub cross type for RS232C is necessary for the data transmission to the PC. Refer to page 40 for the details.

VARIOUS SETTING (MENU/Tools)

Various numerical value can be changed from Tools.

1. On the basic screen, press the menu button (MENU), select "Tools" and press the enter key (ENTER). The setting screen "Select Tools" is displayed.



2. Select the item to be set and press the enter key (ENTER).

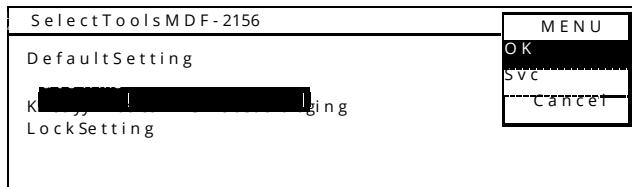

Initialization (Tools/Default Setting)

1. The settlement of each parameter can be done on the default setting screen (Default Setting). (The following shows the default setting)

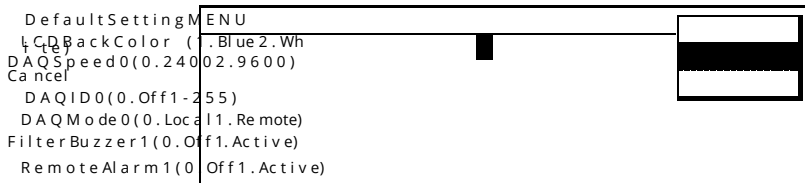

2. After setting, press the menu button (MENU), select "OK" and press the enter key (ENTER) The setting is memorized.

Each parameter setting range:

- LCD Back Color : Setup of the back light (1. Blue 2. White)
- DAQ Speed should use 0, "2400". It is DAQ standard command mode.
- DAQ ID: select any ID between 1 and 250 when an optional interface board is attached.
 - DAQ Mode: "0" setting change from PC side is impossible. "1" change of temperature on the stand-by setting" screen is impossible. "Remote" is indicated on the upper right of the "Stand-by setting" screen. DAQ Mode is effective when DAQ speed is 0 or 2.
- Filter Buzzer can select ON-OFF of the buzzer sound at the time of the filter alarm.
- Remote Alarm can select ON-OFF of the remote alarm at the time of the alarm.

VARIOUS SETTING (MENU/Tools)

Setting of date, time, log interval (Tools/Date Time)

A date, time and a log interval setup screen (Data Time) is indicated. Set up each parameter.

Date Time
MENU
Date 06/07/01 (YY/MM/DD) [blacked out]
Cancel [blacked out]
Time (hh:mm:ss) [blacked out]
Door Delay 15 min
Log Interval 6 min (2-30min)
LC.oCm o mpp DDe ll aa y 5 mi n (2-15mi n)

2. After setting, press the menu button (MENU), select "OK" and press the enter key (ENTER). The setting is memorized.

Each parameter setting range:

● July 1st, 2006 12:00:00 is set.

It is input with 060701 in the Date cell.

It is input with 120000 in the Time cell.

It is set up with MENU/ OK (ENTER).

● Door Delay: The settable range of the door alarm delay time is 1 minute and 15 minutes. (The factory setting is 2 minutes)

● Log Interval: Settable between 2 minutes and 30 minutes. (Factory setting is 15 minutes.) With 15 minutes interval, recording for about 5 weeks is available.

● Comp Delay: Delay time for high temperature side/low temperature side compressor after power failure. The settable range is between 2 minutes until 30 minutes. (Factory setting is 2 minutes.)

VARIOUS SETTING (MENU/Tools)

Setting of key lock password (Tools/Key Lock PW Setting)

1. On the setting screen (Select Tools), select “Key Lock PW Setting”, select “OK” and press the enter key (ENTER). Input the present password (4 digits), select “OK” and press the enter key (ENTER). (Factory setting is 0000.)

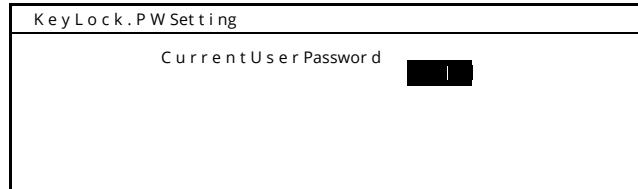

Key Lock . P W Setting

Current User Password []

2. Input a new password, select “OK” and press the enter key (ENTER).

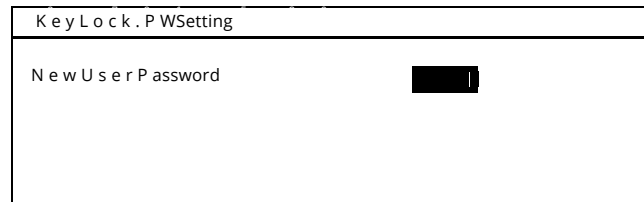

Key Lock . P W Setting

New User Password []

3. Input the password again, select “OK” and press the enter key (ENTER).

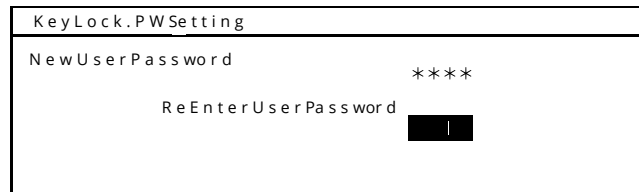

Key Lock . P W Setting

New User Password ****

ReEnter User Password []

ALARM BUZZER

● Temperature alarm buzzer (intermittent tone)

It is informed with the intermittent tone of the buzzer when a high temperature alarm (High Alarm) or a low temperature alarm (Low Alarm) occur.

Buzzer informs it with the intermittent sound when an alarm condition goes on for more than fifteen minutes. Push alarm buzzer stop key (BUZZER) to stop the alarm. The alarm buzzer sounds again if an alarm is not solved in the time when it is set up with Ring Back. When alarm sounds, a remote alarm is activated, too.

● Door alarm buzzer (intermittent tone)

It is informed with the intermittent tone if it is the condition that the door opens beyond the time when it is set up with Door Delay. It stops if a door is closed.

● Filter alarm buzzer (intermittent tone)

It is informed with the intermittent tone when the temperature of filter sensor is beyond +48.0oC
Buzzer sound stops when the temperature of the filter sensor is less than +43.0oC

※: Buzzer stops if the alarm buzzer stop key (BUZZER) is pushed when an alarm occurs and a buzzer sounds.

MONITOR OF FREEZER STATUS

This product has the operation monitor system which shows it in the table 1. It is the system to inform it of the operation conditions of the product. Operation conditions are indicated in the Status indication of the basic screen and the message indication.

Table 1 Operation monitor system (STATUS) list

Kind of function	Status Indication	If this status continues	Remedy
STATUS indication : Notice of abnormal temp. is over approx. 35°C or lower than 0°C. "Ambient temp is abnormal" is indicated.	When the ambient "Status_1" is indicated.	Decrease of cooling performance or Recheck air-conditioning of refrigerating circuit. installed site.	
STATUS indication : Notice of low voltage is between 195 V and 240 V. "The power-supply is abnormal" is indicated.	When the power source voltage is "Status_2" is indicated.	power supply outlet less than approx. or degrade of starting performance of refrigerating circuit	Use dedicated power source.

Note:

- Buzzer operation and a remote alarm can not be done with the monitor of the freezer status.
- STATUS indicates only "STATUS_1" when two problems occur in the monitor of the freezer status. STATUS indicated is to cope with it.

ALARMS & SAFETY FUNCTIONS

This product has the alarm & safety function of the table 2.

Table 2. Alarm & safety function list

Alarm & safety Situation	Indication	Buzzer	Safety operation
High temp. alarm	Alarm lamp flashed If the chamber temperature is higher than the temperature at which the high temperature alarm is activated. Temp. indicator is flashed Message indication: "High Temp. Warning 20XX/XX/XX XX:XX:XX"	Intermittent tone with 15 minutes delay	Remote alarm with 15 minutes delay
Low temp. alarm	Alarm lamp flashed If the chamber temperature is lower than the temperature at which the low temperature alarm is activated. Temp. indicator is flashed Message indication: "Low Temp. Warning 20XX/XX/XX XX:XX:XX"		
Power failure alarm	Alarm lamp flashed When the power to the unit is disconnected. Power failure Warning Message indication: "20XX/XX/XX XX:XX:XX"	Intermittent tone	Remote alarm
Door alarm	When door is open. Door check lamp lights	Intermittent tone with 2 minutes delay	
Filter alarm	When the condenser filter is ON/OFF clogged. Alarm lamp flashed Message indication: "Please check a condenser filter."	Intermittent tone	

Note : A message and an alarm date indicate it in the indication of the high temperature alarm/low temperature alarm/blackout alarm. And, message indication is indicated until an alarm buzzer stop key (BUZZER) is pushed.

ALARMS & SAFETY FUNCTIONS

Table 2. Alarms & safety function list

Alarm & safety Situation	Indication	Buzzer	Safety operation
Operation memory	Record of chamber condition during the power failure. The memory of the set point before the power failure.	-----	The set value is memorized by nonvolatile memory. The freezer resumes the operation with setting before power failure.
Key lock	When the key lock is on. -----	-----	Setup can not be changed.
Auto-return	When there is no key pressing in Chamber temperature is each setting mode for 90 seconds. displayed.	-----	Finishing of each setting mode.
Battery check	When about 3 years has passed with Message indication: power switch ON. "Please exchange batteries."	-----	-----
Fan motor check	When a power switch was turned on Message indication: and it passed for about 6 years. "Please exchange a fan motor."	-----	-----
Sensor abnormality	Message indication: If the thermal sensor is disconnected. "Error E01: Temp sensor is open."	Intermittent tone	Remote alarm. Unit keeps continuous running.
	Message indication: If the thermal sensor is short-circuited. "Error E02: Temp sensor is shorted."	Intermittent tone	Remote alarm. Unit keeps continuous running.
	Message indication: If the cascade sensor is disconnected. "Error E03: Cascade sensor is open."	Intermittent tone	Remote alarm.
	Message indication: If the cascade sensor is short circuited. "Error E04: Cascade sensor is shorted."	Intermittent tone	Remote alarm.
	Message indication: If the filter sensor is disconnected. "Error E05: Filter sensor is open."	Intermittent tone	Remote alarm.
	Message indication: If the filter sensor is short-circuited. "Error E06: Filter sensor is shorted."	Intermittent tone	Remote alarm.
	Message indication: If the ambient temperature sensor is disconnected. "Error E07: Ambient temp sensor is open."	Intermittent tone	Remote alarm.
	Message indication: If the ambient temperature sensor is short-circuited. "Error E08: Ambient temp sensor is shorted."	Intermittent tone	Remote alarm.
Battery switch check	When the battery switch is OFF during Message indication: alarm, test. "Error E09: Battery switch is off."	-----	-----
Condenser temp. abnormality	In the event of failure of fan motor for Message indication: cooling the compressor "Error E10: Condenser temp. is abnormal."	Intermittent tone	Remote alarm. Compressor of high temp. side stops.

Note:

- When the operation is started in high ambient temperature, the alarm lamp (ALARM) sometimes flashes, and then the message (Please check a condenser filter) of the filter alarm is indicated on it in the basic screen. In this case, the lamp is off automatically when the chamber temperature is getting lower.
- The freezer resumes the operation after power failure with the temperature setting before power failure as the chamber temperature setting and alarm temperature setting are memorized in the nonvolatile memory.
- The chamber temperature is displayed for 5 seconds by pressing buzzer stop key (BUZZER) during power failure alarm. Then the buzzer is silenced. The alarm lamp keeps flashing.

REMOTE ALARM TERMINAL

The terminal of the remote alarm is installed at the panel door inside of the unit. The alarm is outputted from this terminal. Contact capacity is DC 30 V, 2 A.

Contact output:

between COM. and N.O. between COM. and N.C.

At normal Open Close

At abnormal Close Open

Note:

The alarm is actuated when the power cord is disconnected from the outlet or the power switch is OFF.

REMOTE ALARM

N.C. COM N.O.

MAX DC30 V 2 A

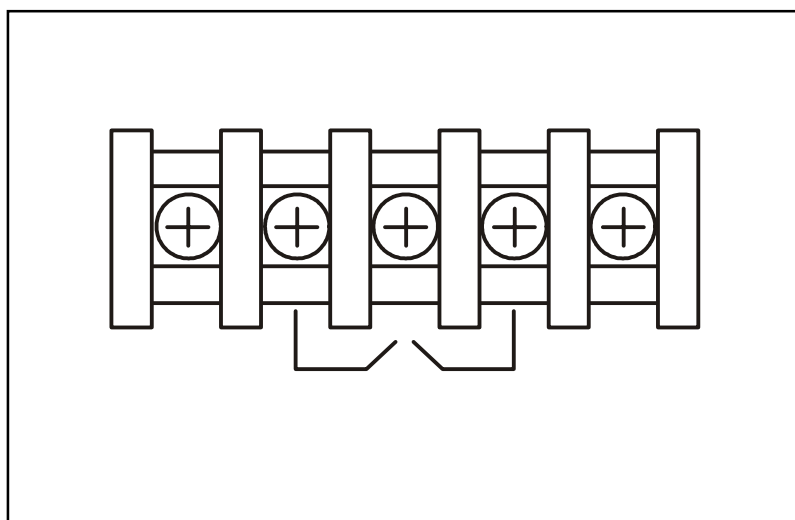

BACKUP COOLING KIT

The holding time of chamber temperature(-135C) due to the change in the ambient temperature.
(Liquid nitrogen : 50 L x 2, no-load)

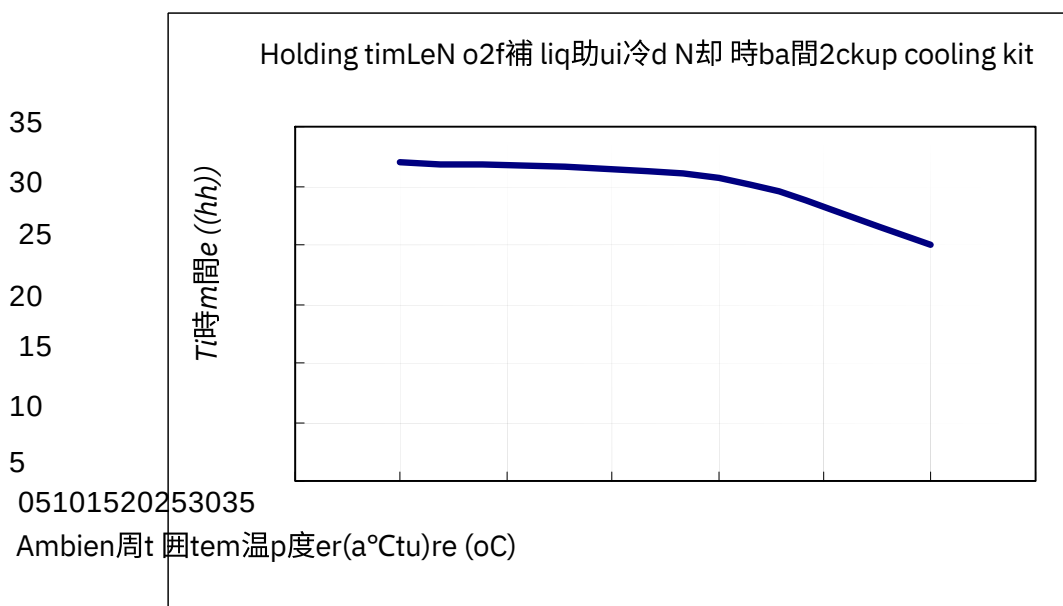

• The above data is the experiment value which uses liquid N₂ 100L. (no-load)

BACKUP COOLING KIT

WARNING

As with any equipment that uses N₂ gas, there is a likelihood of oxygen depletion in the vicinity of the equipment. It is important that you assess the work site to ensure there is suitable and sufficient ventilation. If restricted ventilation is suspected, then other methods of ensuring a safe environment must be considered. These may include atmosphere monitoring and warning devices.

The freezer is provided with an automatic liquid N₂ injection device as a backup cooling kit. This freezer prevents the chamber temperature from going up by injecting the liquid N₂ when the power supply is disconnected (power failure, disconnection of power cord, breaker OFF) or in the case of failure of freezer itself. The liquid N₂ is injected with the activation of solenoid valve energized by battery when the chamber temperature reaches the alarm temperature.

Following shows the procedure for setting the backup cooling kit.

1. Connect the liquid N₂ cylinder with the backup cooling kit joint by using the pipeline and the joint Rough scheme attached with this freezer. This work should be done by high pressure gas works specialists. The pressure of liquid N₂ cylinder should be regulated at 0.5 kg/cm²G.
2. Operate the freezer until the freezer temperature reaches the required level.
3. Set the warning indicator of the recorder at 15°C higher than the freezer temperature.
4. Switch on the liquid N₂ backup. This completes the backup cooling kit setting.
5. Make sure that liquid N₂ spouts into the freezing room with the liquid N₂ backup test switch.
6. This completes the setting of the tank for automatic spouting in case the freezer temperature should match the alarm set temperature.

Note:

- The liquid N₂ gas cylinder is to use an exclusive cylinder.
- There is to be a pressure regulator, and a liquid N₂ gas cylinder is to use the thing that 68.6~49.0 kPaG (0.7~0.5 kg/cm²G) can adjust pressure.
- Use the pipe encloses with the freezer for the setting. (The extension of the pipe is not permitted because of cooling capacity.)
- Turn off a backup switch when the operation of the freezer is suspended and when a backup cooling kit is not used. A battery for the backup cooling kit discharges electricity with on.

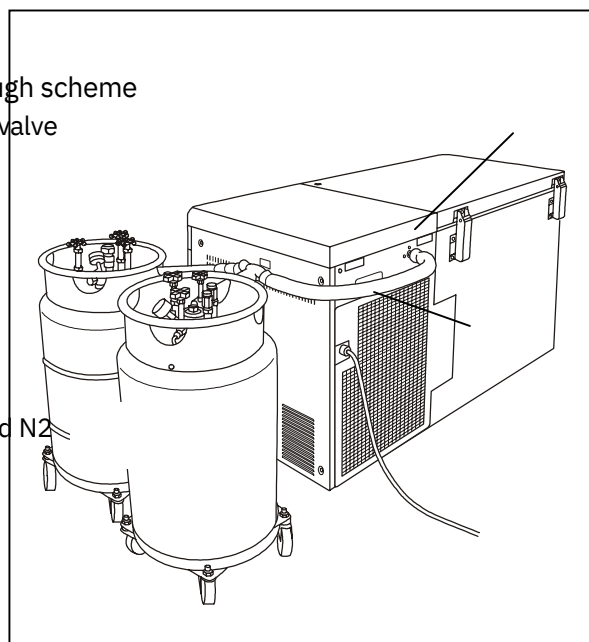

ROUTINE MAINTENANCE

WARNING

Always disconnect the power supply to the unit prior to any repair or maintenance of the unit in order to prevent electric shock or injury. Ensure you do not inhale or consume medication or aerosols from around the unit at the time of maintenance. These may be harmful to your health.

Cleaning of cabinet

- Clean the unit once a month. Regular cleaning keeps the unit looking new.
- Use a dry cloth to wipe off small amounts of dirt on the outside and inside of the unit and all accessories. If the outside panels are dirty, clean them with a diluted neutral dishwashing detergent. (Undiluted detergent can damage the plastic components. For the dilution, refer to the instruction of the detergent.) After the cleaning with the diluted detergent, always wipe it off with a wet cloth. Then wipe off the cabinet or accessories with a dry cloth.
- Never pour water onto or into the unit. Doing so can damage the electric insulation and cause failure.
- The compressor and other mechanical parts are completely sealed. This unit requires absolutely no lubrication.
- Check the backup cooling kit by pressing test switch once a month if it is installed.
- Remove the frost or ice on the chamber wall and clean the condenser filter once a month.

Cleaning of condenser filter

This unit is provided with the alarm lamp on the control panel. Clean the filter when this lamp flashed. Clean the filter once a month even if the alarm lamp is not on since a clogged filter may cause shorter compressor life as well as the poor cooling. Clean the filter by the procedure below.

1. Open the grille by pulling it to you as shown in the figure.
2. Take out the condenser filter.
3. Wash the filter with water.
4. Replace the filter and the grille.
5. Check that the alarm lamp is off in the event the check lamp was ON.

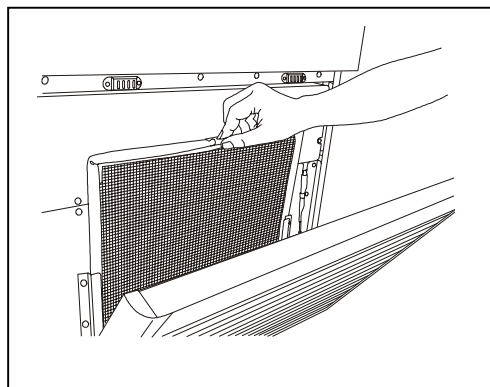

WARNING

Do not touch the condenser directly when the filter is removed for cleaning. This may cause injury by hot surface.

ROUTINE MAINTENANCE

Defrosting of inside wall

Defrost the inside wall of the freezer as follows:

Normal defrosting

Remove the frost by the enclosed scraper.

Thorough defrosting

1. Take out and transfer all the contents to another freezer or container which contains liquid N₂, or dry ice. Switch off the remote alarm and backup cooling kit. Switch off the power supply.
2. Open the door and remove the inner lid. Leave the freezer as it is. The water remaining in the freezer compartment should be wiped up.
3. After cleaning is completed, restart the operation according to the procedure. Put back the articles into the sufficiently cooled freezer compartment.

REPLACEMENT OF BATTERY

The battery for power failure alarm is an article for consumption. The battery life is approximately 3 years. The buzzer cannot be activated at the power failure and the stored items may be influenced if the battery is left as it is for more than 3 years. It is recommended that the battery is replaced ahead of time. For the replacement of the battery, contact our sales representative or agent.

Location of a lead storage battery

This unit is provided a lead storage battery for the power failure warning device. The battery is located in the battery box inside the side table. (Fig. 1)



The high voltage components are enclosed in the battery box. The cover should be removed by a qualified engineer or a service personnel only to prevent the electric shock.

Removal of lead storage battery

1. Turn off the power switch, battery switch and disconnect the power supply plug.

2. Lift the handle of the side table to the top as shown in the fig. 2, and open the door of the side table.

Remove 6 screws of the battery box cover, and remove a battery box cover.

Remove 4 screws which fix a battery bracket on the side table. (Fig. 3)

Remove the connector of the battery, and take out a battery bracket from the side table. And remove 4 screws of the battery bracket which fixes a battery (4 pcs). (Fig. 4)

Handling of the lead storage battery:

Cover the battery terminal with an insulating tape to avoid the short circuit. Then follow the procedure for recycling or proper disposal.

Side table

Side table

Battery Battery box
cover

Screw

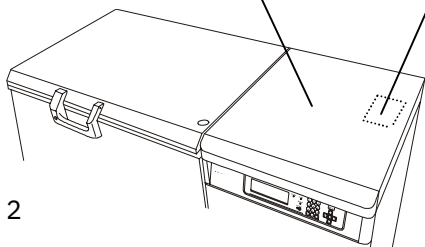

Fig. 1 Fig. 2

Screw

Battery Screw

Connector

Battery

bracket

Screw

Screw

Fig. 3 Fig. 4

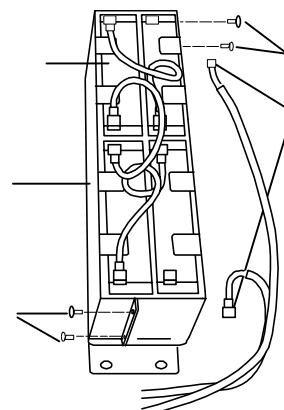
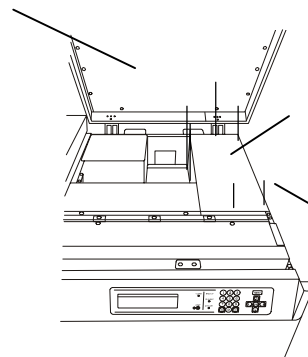
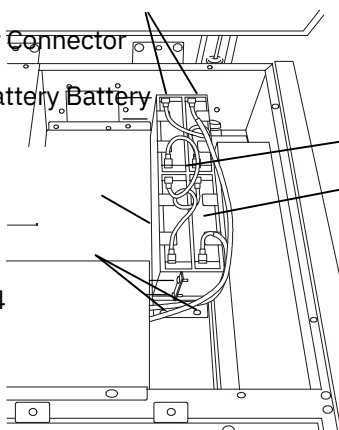

TROUBLESHOOTING

If the unit malfunctions, check out the following before calling for service.

Malfunction	Check/Remedy
If nothing operates even when switched on	The unit is not connected to the power supply.
The fuse is blown or the circuit breaker is activated.	There is a power failure.
An alarm system works when use starts.	Investigate the following cause when an alarm lamp and buzzer sound are working.
Is temperature of the freezer chamber when it is using.	<ul style="list-style-type: none"> ■ Is the value the value? ■ Were not you taking the condition that opened the change of the temperature command and a door for a long time? ■ Did not you put the sample whose temperature was high in the freezer chamber?
An alarm is canceled naturally	when it is left in these cases.
The cooling is poor	The environmental temperature is too high.
The door is not shut tightly.	<ul style="list-style-type: none"> ■ ■ The inner lid is not installed correctly.
The set temperature is not set properly.	
The grille is blocked out.	■
The filter is clogged.	■
The freezer is in the direct sunlight.	■
There is any heating source near the freezer.	■
A rubber cap and insulation for the access port are not set correctly.	■
You put too many unfrozen articles into the freezer compartment.	■
There is condensation outside the freezer installation site, or under muggy environment. The condensation is caused by the humidity not by freezer failure.	<ul style="list-style-type: none"> ■ The condensation can be found outside the freezer depending on the site, or under muggy environment. The condensation is caused by the humidity not by freezer failure. ■ Wipe off the condensation with a dry cloth.

Note:

If the malfunction is not eliminated after checking the above items, or the malfunction is not shown in the above table, contact our sales representative or agent.

DISPOSAL OF UNIT

WARNING

If the unit is to be stored unused in an unsupervised area for an extended period ensure that children do not have access and doors cannot be closed completely.

The disposal of the unit should be accomplished by appropriate personnel. Always remove doors to prevent accidents such as suffocation.

Recycle of battery



The unit contains a rechargeable battery. The battery is recyclable. At the end of its useful life, check with your local solid waste officials for an option or proper disposal.



*Label indication is obliged to comply with Taiwanese battery regulation.

DISPOSAL OF UNIT

Note:

This symbol mark and recycle system are applied ~~only to EU countries~~ and not applied to the countries in the other area of the world.

Waste Electrical and Electronic Equipment (WEEE) Directive-2002/96/EC

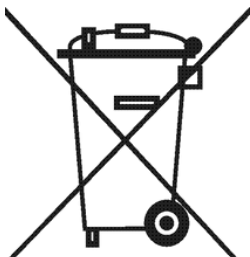

(English)

Your Panasonic product is designed and manufactured with high quality materials and components which can be recycled and reused.

This symbol means that electrical and electronic equipment, at their end-of-life, should be disposed of separately from your household waste.

Please dispose of this equipment at your local community waste collection/recycling centre.

In the European Union there are separate collection systems for used electrical and electronic products.

Please help us to conserve the environment we live in!

(German)

Ihr Panasonic Produkt wurde entworfen und hergestellt mit qualitativ hochwertigen Materialien und Komponenten, die recycelt und wiederverwendet werden können.

Dieses Symbol bedeutet, daß elektrische und elektronische Geräte am Ende ihrer Nutzungsdauer von Hausmüll getrennt entsorgt werden sollen.

Bitte entsorgen Sie dieses Gerät bei Ihrer örtlichen kommunalen Sammelstelle oder im Recycling Centre.

In der Europäischen Union gibt es unterschiedliche Sammelsysteme für Elektrik- und Elektronikgeräte.

Helfen Sie uns bitte, die Umwelt zu erhalten, in der wir leben!

DISPOSAL OF UNIT

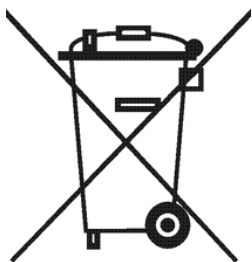

(French)

Votre produit Panasonic est conçu et fabriqué avec des matériaux et des composants de qualité supérieure qui peuvent être recyclés et réutilisés.

Ce symbole signifie que les équipements électriques et électroniques en fin de vie doivent être éliminés séparément des ordures ménagères.

Nous vous prions donc de confier cet équipement à votre centre local de collecte/recyclage.

Dans l'Union Européenne, il existe des systèmes sélectifs de collecte pour les produits électriques et électroniques usagés.

Aidez-nous à conserver l'environnement dans lequel nous vivons !

Les machines ou appareils électriques et électroniques contiennent fréquemment des matières qui, si elles sont traitées ou éliminées de manière inappropriée, peuvent s'avérer potentiellement dangereuses pour la santé humaine et pour l'environnement.

Cependant, ces matières sont nécessaires au bon fonctionnement de votre appareil ou de votre machine. Pour cette raison, il vous est demandé de ne pas vous débarrasser de votre appareil ou machine usagé avec vos ordures ménagères.

(Spanish)

Los productos Panasonic están diseñados y fabricados con materiales y componentes de alta calidad, que pueden ser reciclados y reutilizados.

Este símbolo significa que el equipo eléctrico y electrónico, al final de su ciclo de vida, no se debe desechar con el resto de residuos domésticos.

Por favor, deposite su viejo equipo en el punto de recogida de residuos o contacte con su administración local.

En la Unión Europea existen sistemas de recogida específicos para residuos de aparatos eléctricos y electrónicos.

Por favor, ayúdenos a conservar el medio ambiente!

DISPOSAL OF UNIT

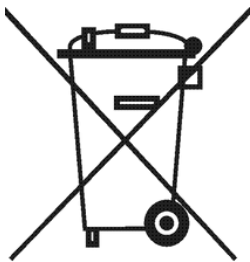

(Portuguese)

O seu produto Panasonic foi concebido e produzido com materiais e componentes de alta qualidade que podem ser reciclados e reutilizados.

Este símbolo significa que o equipamento eléctrico e electrónico no final da sua vida útil deverá ser descartado separadamente do seu lixo doméstico.

Por favor, entregue este equipamento no seu ponto local de recolha/reciclagem.

Na União Europeia existem sistemas de recolha separados para produtos eléctricos e electrónicos usados.

Por favor, ajude-nos a conservar o ambiente em que vivemos!

(Italian)

Il vostro prodotto Panasonic è stato costruito da materiali e componenti di alta qualità, che sono riutilizzabili o riciclabili.

Prodotti elettrici ed elettronici portando questo simbolo alla fine dell'uso devono essere smaltiti separatamente dai rifiuti casalinghi.

Vi preghiamo di smaltire questo apparecchio al deposito comunale.

Nell'Unione Europea esistono sistemi di raccolta differenziata per prodotti elettrici ed elettronici.

Aiutateci a conservare l'ambiente in cui viviamo!

DISPOSAL OF UNIT

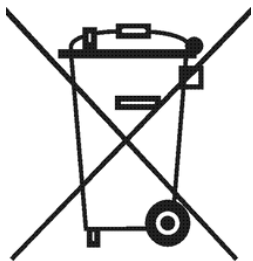

(Dutch)

Panasonic producten zijn ontwikkeld en gefabriceerd uit eerste kwaliteit materialen, de onderdelen kunnen worden gerecycled en weer worden gebruikt.

Het symbool betekent dat de elektrische en elektronische onderdelen wanneer deze vernietigd gaan worden, dit separaat gebeurt van het normale huisafval.

Zorg ervoor dat het verwijderen van de apparatuur bij de lokaal erkende instanties gaat gebeuren. In de Europese Unie wordt de gebruikte elektrische en elektronische apparatuur bij de daarvoor wettelijke instanties aangeboden.

Alstublieft help allen mee om het milieu te beschermen.

(Swedish)

Din Panasonic produkt är designad och tillverkad av material och komponenter med hög kvalitet som kan återvinnas och återanvändas.

Denna symbol betyder att elektriska och elektroniska produkter, efter slutanvändande, skall sorteras och lämnas separat från Ditt hushållsavfall.

Vänligen, lämna denna produkt hos Din lokala mottagningstation för avfall/återvinningsstation.

Inom den Europeiska Unionen finns det separata återvinningssystem för begagnade elektriska och elektroniska produkter.

Vänligen, hjälp oss att bevara miljön vi lever i!

TEMPERATURE RECORDER (OPTION)

WARNING

Disconnect the power supply plug before attaching the temperature recorder or it may cause electric shock or fire.

An automatic temperature recorder is available for this freezer as the optional component. The type of the recorder is MTR-155H. Consult our sales representative or agent for the recorder installation. Following shows the installation procedure.

<The installation method of MTR-155H>

1. Remove four screws (shown by arrows) on the front. After that, remove a temperature recorder cover (4 Panel door

Screw screws).

Temperature recorder cover

Screw

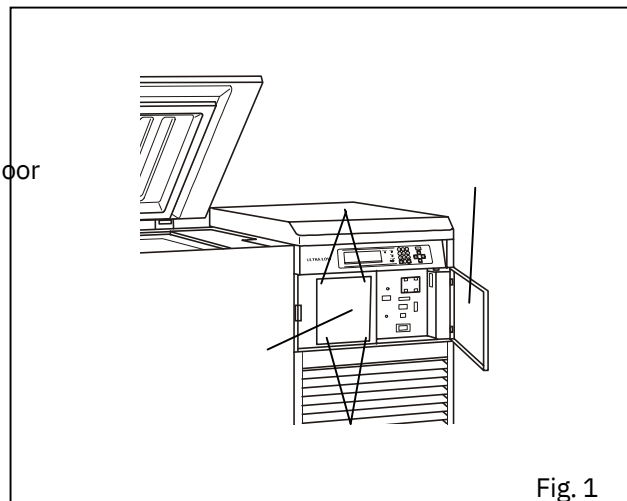

2. Remove the recorder sensor cover (2 screws) of the inside (the right back front) of the freezer. (Fig. 2)

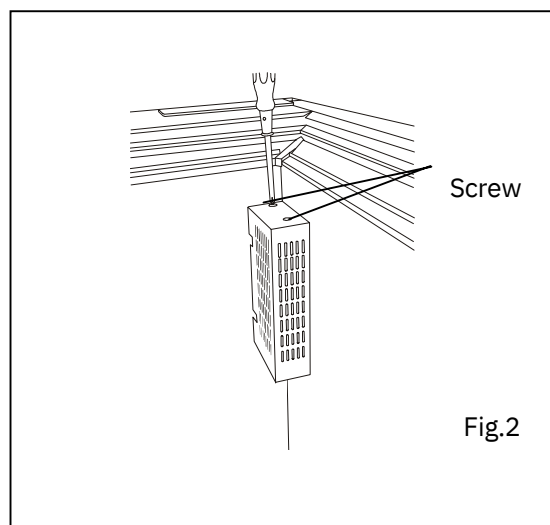

3. Pass a recorder sensor through the inside of the freezer, and use the clip of the recorder sensor cover, and fix a recorder sensor with a screw. Seal the recorder sensor hole with a silicone caulking. (Fig. 3)

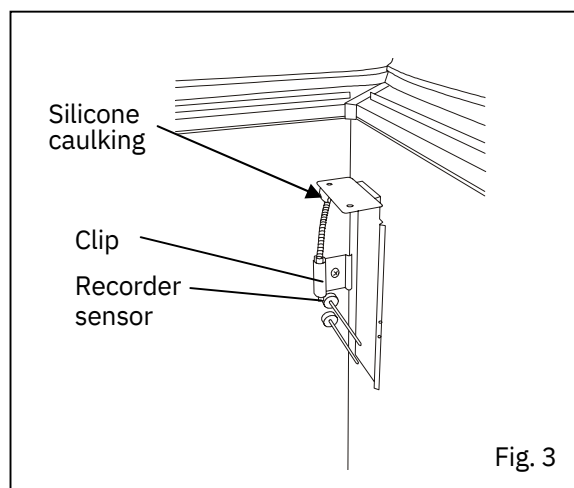

TEMPERATURE RECORDER (OPTION)

4. Pass a recorder sensor through the inside of the freezer in the hole (It is blocked with the rubber stopper and the insulation in this hole. Remove it first.) for the recorder sensor. (Fig. 4)

Rubber

5. Fix a recorder sensor cover with 2 screws. (Fig. 2) stopper Fig.4

6. Bind the extra lead wire of the sensor with a nylon clip on the back of the temperature recorder. (Fig. 4)

7. As shown in the Fig. 5, insert the temperature recorder by using the recorder fixing(MDF-S30150) and temperature recorder fitting to the mounting space and fix it to the front side of the front panel. Fix with four screws.

Temperature recorder fitting

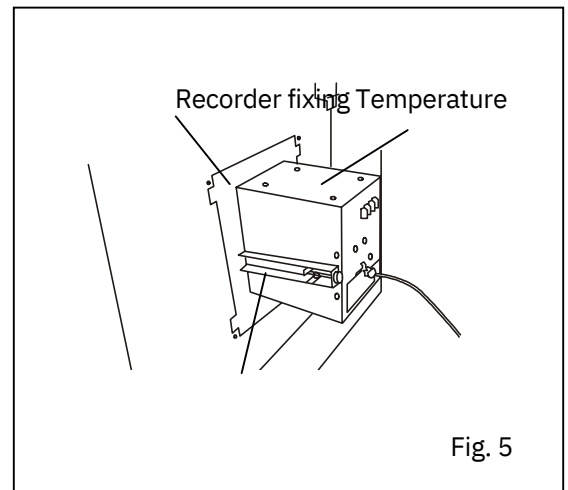
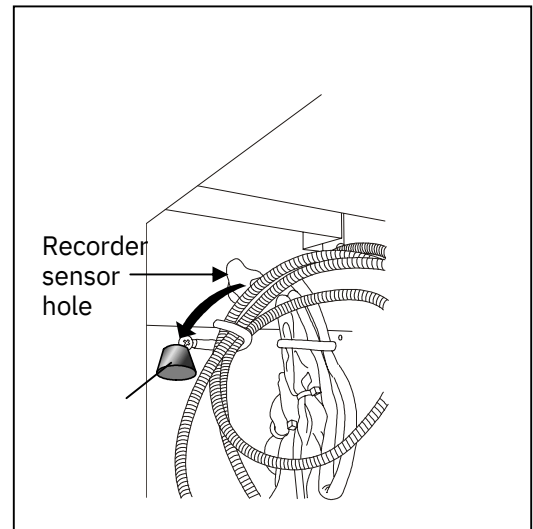

8. Check that setup temperature is the same as chamber temperature of the freezer.

After that, record indication temperature of the recorder and the freezer internal temperature indication of the control panel. Adjust it to freezer internal indication temperature with a zero adjustable screw of the recorder when indication temperature of the recorder and freezer internal temperature indication deviate.

TEMPERATURE RECORDER (OPTION)

⚠WARNING

Disconnect the power supply plug before attaching the temperature recorder or it may cause electric shock or fire.

The figure below shows the description of a temperature recorder.

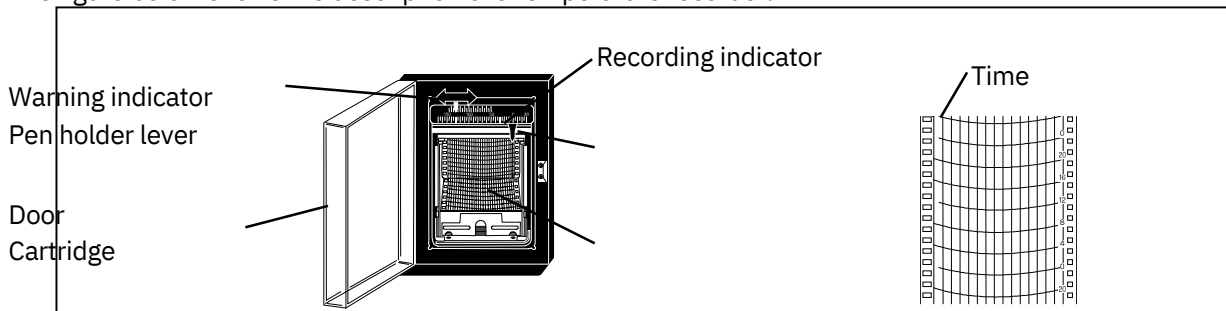

Feeding of recording paper

1. Open the door and let down the lever of the penholder; the pen point is apart from the recording paper. (Fig. 1)

2. Pull the cartridge out of the mounted position. (Fig. 2)

3. Set a new recording paper in place on the rear bottom of the cartridge. Set the hole on the recording paper in the cog of the recording paper driving assembly and feed the recording paper in Fig. 1 the direction of the arrow by driving the cog wheel.

4. Set the recording paper according to the mark of day and time. (Fig. 3)

5. When mounting, lay down the cartridge first, and push into the mounting position with the groove set a the projection on the position.

6. Set up the cartridge and settle in position. Fig. 3

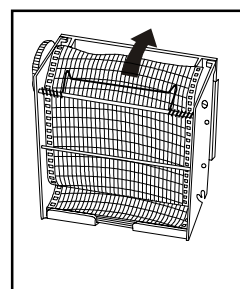
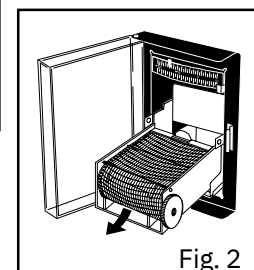
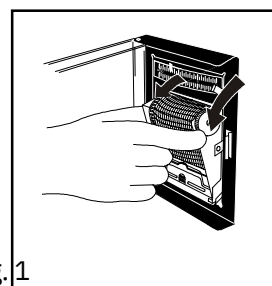

Replacement of battery

Replace the battery once a year as follows:

1. Put up the penholder lever first, then pull out cartridge from the mounted position.

2. Reset the battery chamber cover with wire, on the bottom left side, and take out the cell.

3. Set a new cell by turning its anode to this side.

4. Shut the cover after exchanging battery. Mount the cartridge Battery as before and lay down the penholder lever.

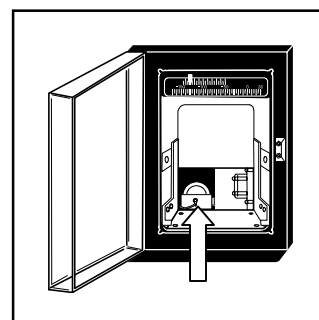

Note :

This temperature recorder is designed for the manganese battery and the alkaline battery.

Do not use a rechargeable battery because the initial voltage of such battery is low. The rechargeable battery may cause the malfunction of recorder or shorten the battery life significantly.

Setting of backup temperature

1. There is a red guide on the top of the temperature displayer. Adjust the guide with your finger to backup temperature, at which temperature the auxiliary cooling system starts to operate.

2. Set at a temperature 15°C higher than that of the freezer compartment.

TEMPERATURE RECORDER (OPTION)

Penholder

Install a ink pen in the recording hand as shown in the figure. Make sure that the ink pen is completely inserted for accurate recording. The ink pen is packed together with the recording paper.

1. Let down the lever of the penholder, then pull out the cartridge from the mounted position.
2. Insert a new ink pen.
3. Mount the cartridge into place.
4. Lift up the penholder lever and make sure that the ink pen point touches the recording paper.

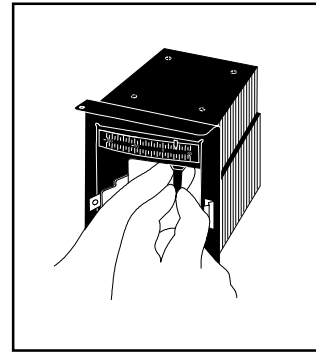

MOUNTING OF INTERFACE BOARD (OPTION)

By installing an interface board (MTR-480), the log data can be transmitted to a PC. The mounting procedure is as follows:

1. Remove 4 screws of the communication box hole cover in the control panel. (Fig. 1)
2. Provide an interface board (MTR-480) code from the fitting hole. (Fig. 2)
3. Refer to the instruction manual attached to the interface board for the setup of the TERMINATOR switch of the interface board (MTR-480). (Fig. 3)
4. Connect to the connector side (the back side of the interface board) of a communication cable (RS-232C or RS-485) to use for the interface board (MTR-480). (Fig. 5 is a connection example to use RS-232C.) (Fig. 4 and 5)
5. Fix an interface board (MTR-480) on the control panel with 4 screws. (Fig. 6)

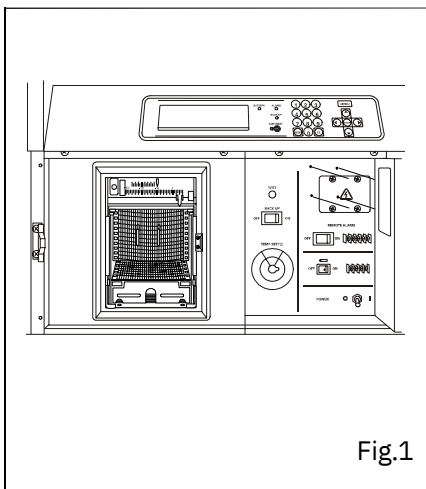

Fig.1

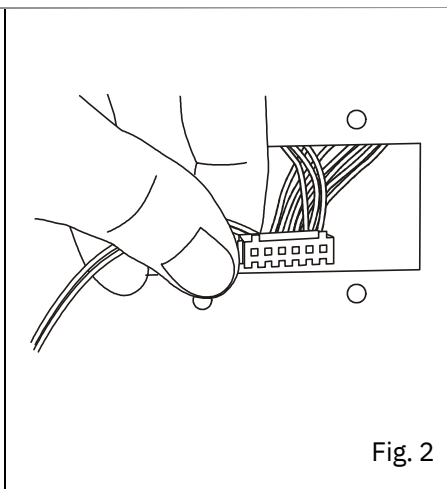

Fig. 2

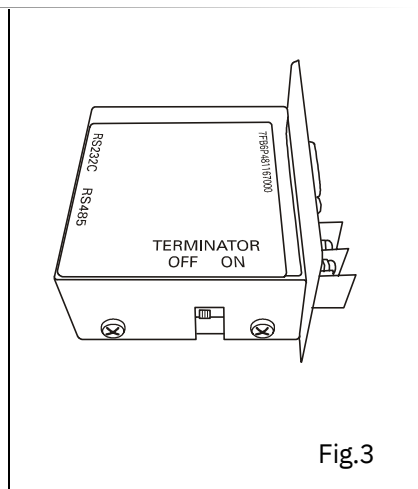

Fig.3

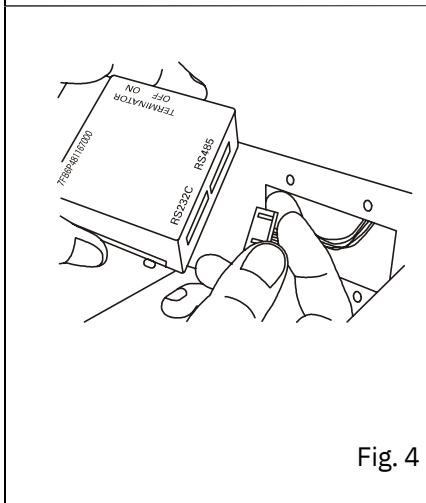

Fig. 4

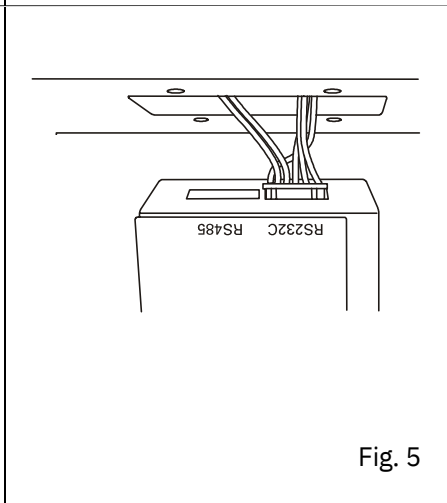

Fig. 5

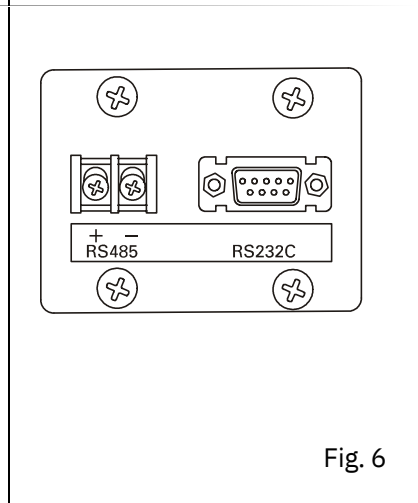

Fig. 6

* When a data transmitting function to the personal computer is done, an interface board MTR-480 (option goods) and communication cable of 9 pin Dsub cross type for RS232C are necessary.

SPECIFICATIONS

Product name	Ultra-Low Temperature Freezer Ultra-Low Temperature Freezer
MDF-C2156VAN	MDF-C2156VANC
External dimensions	W1730 mm x D765 mm x H1010 mm
Internal dimensions	W760 mm x D495 mm x H615 mm
Effective capacity	231 L
Exterior	Painted steel
Interior	Aluminum plate
Outer door	Painted steel
Inner door	Rigid polyurethane foamed-in place
Access port	40 mm diameter, 1 locations (in the side table)
Insulation	Vacuum insulation panel + Rigid polyurethane foamed-in place
Compressor	High stage side; Hermetic type, Output; 1100 W Low stage side; Hermetic type, Output; 1100 W
Evaporator	High stage side; Cascade condenser type, Low stage side; Tube on sheet type
Condenser	High stage side; Fin and tube type, Low stage side; Auto cascade type
Refrigerant	High stage side; R-407D, Low stage side; HFC mixed refrigerant
Temperature controller	Microcomputer control system
Temperature display	Digital display
Thermal sensor	Platinum resistance (Pt 1000Ω)
Alarm	High temp. alarm, Low temp. alarm, Power failure alarm, Door alarm
Filter check	
Remote alarm contact	Allowable contact capacity: DC 30 V, 2 A
Battery	Lead storage battery, DC 6 V, 7.2 Ah x 4pcs, Auto-recharge
Accessories	1 set of key, 1 scraper, 1 set connect tube for backup cooling kit
Weight	318 kg 325 kg
Voltage booster	None Built-in
Optional component	Automatic temperature recorder + Recorder fixing (MTR-155H + MDF-S30150)
Interface board	(MTR-480)
Inventory rack	(IR-207C, MDF-49SC)
Note:	

- Design or specifications will be subject to change without notice.
- Refer to the updated catalog when ordering an optional component.
- The battery for power failure alarm is an article for consumption. It is recommended that the battery will be replaced about every 3 years. Contact our sales representative or agent at the time of replacement of the battery for recycling.
- Fan motors are expendable supplies. Exchange it for about every 6 years. Contact our sales representative or agent at the time of replacement of the fan motor.
- When a data transmitting function to the personal computer is done, an interface board MTR-480 (option) and communication cable of 9 pin Dsub cross type for RS232C are necessary.

PERFORMANCE

Product name Ultra-Low Temperature Freezer MDF-C2156VAN/MDF-C2156VANC			
Model No. MDF-C2156VAN-PA	MDF-C2156VAN-PB	MDF-C2156VAN-PK	MDF-C2156VAN-PE
MDFC2156VANC-PA			
Cooling performance -150oC at the center of the chamber (ambient temperature; 30oC, no load)			
Temperature control range -125oC to -150oC (ambient temperature; 30oC, no load)			
Power source 220 V	220 V AC	230 V/240 V	
Power source 50 Hz	60 Hz	50 Hz	
Rated power consumption 1550 W	1700 W	1550 W/1600 W	
Noise level 51 dB [A] (background noise; 20 dB)			
Maximum pressure 3085 kPa			

Note :

- Specifications will be subject to change without notice.
- The unit with CE mark complies with EC directives.

⚠ CAUTION

Please fill in this form before servicing.
Hand over this form to the service engineer to keep for his and your safety.

Safety check sheet

1. Freezer contents : Yes No
Risk of infection: Yes No
Risk of toxicity: Yes No
Risk from radioactive sources: Yes No

(List all potentially hazardous materials that have been stored in this unit.)

Notes :

2. Contamination of the unit:

- Unit interior: Yes No
No contamination: Yes No
Decontaminated: Yes No
Contaminated: Yes No
Others:

3. Instructions for safe repair/maintenance of the unit

- a) The unit is safe to work on Yes No
b) There is some danger (see below) Yes No
Procedure to be adhered to in order to reduce safety risk indicated in b) below.

Date :

Signature :

Address, Division :

Telephone :

Product name: Ultra-low temperature freezer	Model: MDF-	Serial number:	Date of installation:
---	----------------	----------------	-----------------------

Please decontaminate the unit yourself before calling the service engineer.