

# SW Series

## *Super Washdown Scales*

SW-6KS / SW-15KS

SW-15KM / SW-30KM / SW-60KM / SW-150KM

SW-60KL / SW-150KL

# INSTRUCTION MANUAL



## Warning Definition

The warning described in this manual has the following meaning:

 <b>DANGER</b>	An imminently hazardous situation which, if not avoided, will result in death or serious injury.
---	--

© 2011 A&D Company, Limited. All rights reserved.

No part of this publication may be reproduced, transmitted, transcribed, or translated into any language in any form by any means without the written permission of A&D Company, Limited.

The contents of this manual and the specifications of the instrument covered by this manual are subject to change for improvement without notice.

---

# CONTENTS

---

<b>1. COMPLIANCE</b> .....	3
<b>2. INTRODUCTION</b> .....	4
<b>3. FEATURES</b> .....	4
<b>4. PRECAUTIONS</b> .....	5
4.1. Installing the scale .....	5
4.2. Operating the scale .....	5
4.3. Cleaning the scale .....	6
<b>5. UNPACKING</b> .....	6
<b>6. DESCRIPTION OF EACH PART</b> .....	7
6.1. Display and symbols .....	8
6.2. Keys .....	9
<b>7. SETTING UP</b> .....	10
7.1. Attaching the display pole to the base .....	10
7.2. Installing the scale .....	11
<b>8. BASIC OPERATION</b> .....	12
8.1. Turning the power ON and OFF .....	12
8.2. Selecting a weighing unit.....	13
8.3. Basic weighing operation.....	13
8.4. Weight display resolution.....	14
<b>9. COUNTING MODE</b> .....	15
<b>10. COMPARATOR</b> .....	16
10.1. The formula to compare .....	17
10.2. Entering the comparator values.....	18
<b>11. AUTO-TARE FUNCTION</b> .....	19
<b>12. CALIBRATION</b> .....	20
12.1. Calibration mode .....	20
12.2. Gravity acceleration correction .....	21
12.3. Calibration using a weight .....	22

12.4. Restoring the factory set values .....	23
<b>13. FUNCTIONS</b> .....	<b>24</b>
13.1. Setting the parameters .....	24
13.2. Restoring the function settings to the factory set values .....	24
13.3. Function list .....	25
<b>14. OPTIONS</b> .....	<b>27</b>
14.1. Using the HC-02i battery .....	27
14.1.1. Installing the battery .....	27
14.1.2. Charging the battery.....	28
14.2. SW-03 RS-232C / RELAY OUTPUT.....	29
14.2.1. Installing SW-03.....	29
14.2.2. SW-03 specifications .....	31
14.2.3. Command mode .....	34
14.3. SW-04 RS-422 / 485 .....	39
14.3.1. Installing SW-04.....	39
14.3.2. SW-04 specifications .....	40
<b>15. MAINTENANCE</b> .....	<b>43</b>
15.1. Notes on maintenance.....	43
15.2. Error codes.....	43
<b>16. SPECIFICATIONS</b> .....	<b>44</b>
16.1. Specifications .....	44
16.2. External dimensions .....	46
<b>GRAVITY ACCELERATION MAP</b> .....	<b>48</b>

---

# 1. COMPLIANCE

---

## Compliance with FCC rules

- Please note that this equipment generates, uses and can radiate radio frequency energy. This equipment has been tested and has been found to comply with the limits of a Class A computing device pursuant to Subpart J of Part 15 of FCC rules. These rules are designed to provide reasonable protection against interference when equipment is operated in a commercial environment. If this unit is operated in a residential area it might cause some interference and under these circumstances the user would be required to take, at his own expense, whatever measures are necessary to eliminate the interference.

(FCC = Federal Communications Commission in the U.S.A.)

## Classification of protection provided by enclosures

- The equipment is designed to comply with the IP Code of IEC 60529. The "IP69K" is explained as follows:

"IP" International Protection.

"6" Against ingress of solid foreign objects.  
Dust-tight. No ingress of dust.

"9K" Against ingress of water with harmful effects.  
High pressure water jets directed against the enclosure from any direction shall have no harmful effects. (DIN40050 Part 9)

## NSF listed

- Applicable only to the NSF Certified models. The NSF Certified models have the NSF Mark attached on the display.
- The equipment is certified and listed to NSF/ANSI Standard 169 by NSF International. NSF International evaluated the equipment and certified that it is compliant with food protection and sanitation requirements for the design, construction and materials.

(NSF = National Sanitation Foundation)

---

## 2. INTRODUCTION

---

This manual describes how the SW Series Super Washdown Scales work and how to get the most out of them in terms of performance. Please read this manual completely before using the scale.

---

## 3. FEATURES

---

The SW Series Super Washdown Scales have the following features:

- Dust-tight and water-tight construction, complying with IP69K.
- The weighing platforms and weighing pans are made of stainless steel (SUS304).
- The weighing platforms are designed for easy cleaning and not to collect dust. Three sizes of weighing platform are available.
- Employing touch-sensitive keys enabled the display to be covered with a plastic sheet, resulting in better dust-tight and water-tight performance. When a key is touched, the corresponding LED, above that key, turns on to indicate that the key has been touched.
- A bright LED display, with a broad viewing angle.
- Three types of weight display resolution are available to cover various applications, 1/3,000, 1/6,000 (1/7,500 for some models) and 1/12,000 (or 1/15,000 for some models). (To be selected in the function setting.)

Note: The weight display resolution of the Legal for Trade models is fixed. The selection in the function setting is not available.

- The counting mode easily counts the number of objects of the same weight.
- The comparator mode compares the displayed value (weight value) with the previously set comparator values and indicates the results by the large and bright LED display. The optional comparator relay output (SW-03) can output the results as a relay signal.
- The auto-tare function, used with the comparator mode, automatically tares and displays "OK" for a certain amount of sample and repeats this process with the next weighing.
- Available weighing units are kg (kilogram), g (gram), lb (pound), oz (ounce), lb-oz (pound and ounce) and pcs (pieces for the counting mode).
- The optional RS-232C serial interface (SW-03) or optional RS-422/485 serial interface (SW-04) can transmit the weight value to a printer or personal computer.
- The optional sealed lead acid (SAL) battery (HC-02i) can be installed, allowing the scale to be used where an AC power source is not available.

---

## 4. PRECAUTIONS

---

### 4.1. Installing the scale

 <b>DANGER</b>
<ul style="list-style-type: none"><li>• <b>Ground the scale so that the user will not be subject to an electric shock.</b></li><li>• <b>The base frame is connected to the power GND (EXC-) inside the load cell. Be sure to earth ground the AC power cable. When the AC electrical outlet has no ground terminal, use the ground terminal (screw with the ground symbol) on the scale.</b><ul style="list-style-type: none"><li>Location of the ground terminal<ul style="list-style-type: none"><li>Models with a display pole: lower part of the display pole</li><li>Models with no display pole: bottom of the weighing pan</li></ul></li></ul></li><li>• <b>Do not handle the AC power cable with wet hands.</b></li><li>• <b>The AC plug is not water-resistant. Use an electrical outlet located at a place where the plug will not get wet.</b></li><li>• <b>Even when the optional sealed lead acid (SLA) battery (HC-02i) is used, be sure to prevent the AC plug from getting wet.</b></li><li>• <b>Do not handle the cables carelessly.</b></li><li>• <b>Do not install the scale where flammable or corrosive gas is present.</b></li></ul>

Consider the following conditions to get the most from your scale.

- Install the scale where the temperature and relative humidity are stable, with no drafts or vibration.
- Install the scale on a solid and level surface.
- Do not install the scale in direct sunlight.
- Do not install the scale near heaters or air conditioners.
- Do not install the scale near equipment which produces magnetic fields.
- Do not install the scale in a place where it is possible to be charged with static electricity, or where the relative humidity is lower than 45% RH. Insulators such as plastic are often charged with static electricity.
- Use a stable power source.
- Calibrate the scale before use or after having moved it to another location.  
In addition, calibrate it periodically to maintain the accuracy.  
(Refer to “12. CALIBRATION”).

### 4.2. Operating the scale

- Periodically ensure that the scale weighs correctly.
- Calibrate the scale periodically to maintain the weighing accuracy (Refer to “12. CALIBRATION”).
- Do not place anything on the pan that is beyond the weighing capacity.
- Do not apply a shock load to the scale.
- Touch the keys only with a finger.
- Confirm zero before each weighing to prevent possible error.

### 4.3. Cleaning the scale

- Do not disassemble the scale.
- Do not use solvents to clean the scale.
- The scale can be washed with water completely.

---

## 5. UNPACKING

---

When unpacking, check whether all of the following items are included:

Instruction manual

SW series scale

The scale components are different depending on the type of scale.

With a display pole (no display stand)

With a display stand (no display pole)

With no display pole or display stand



---

## 6. DESCRIPTION OF EACH PART

---

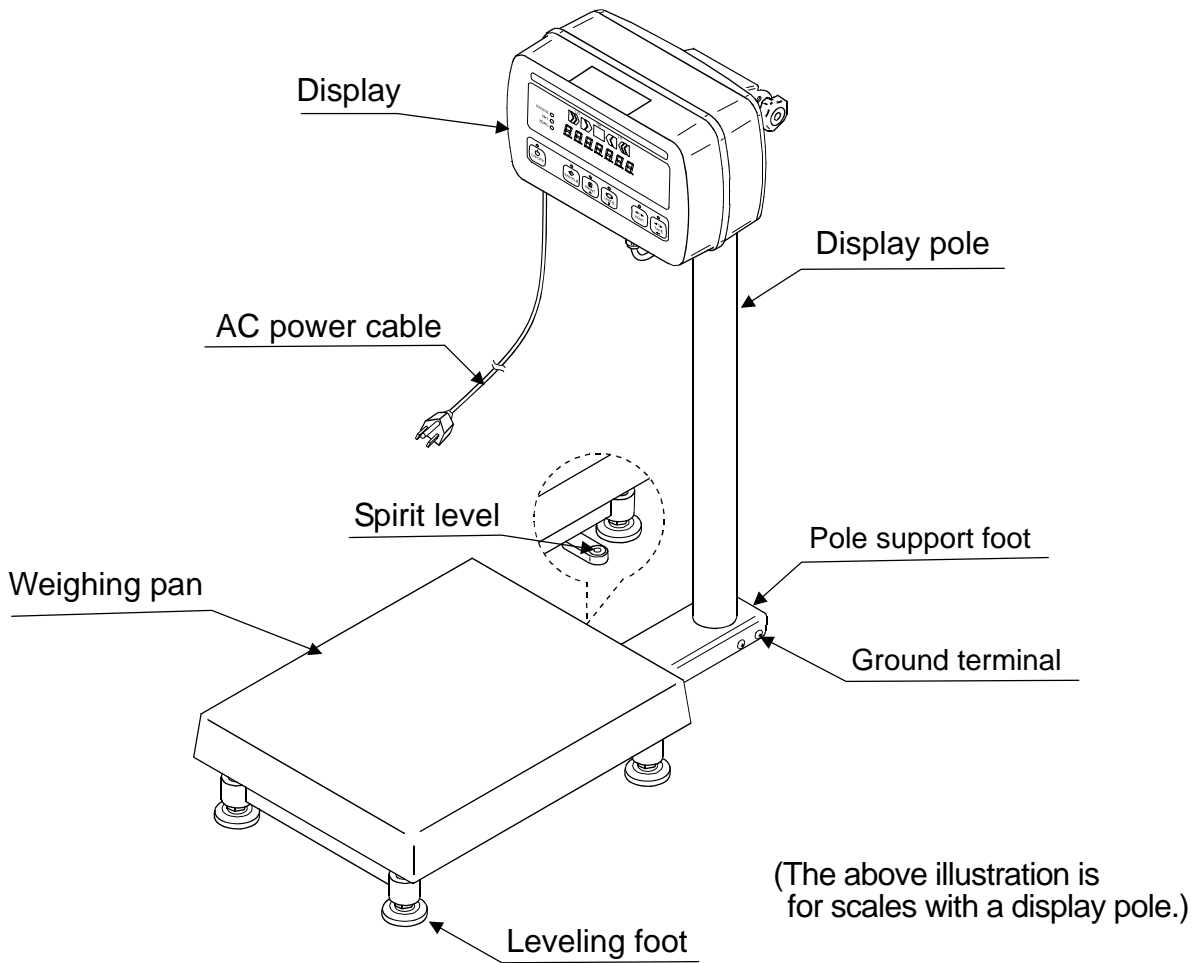

### Display rear side

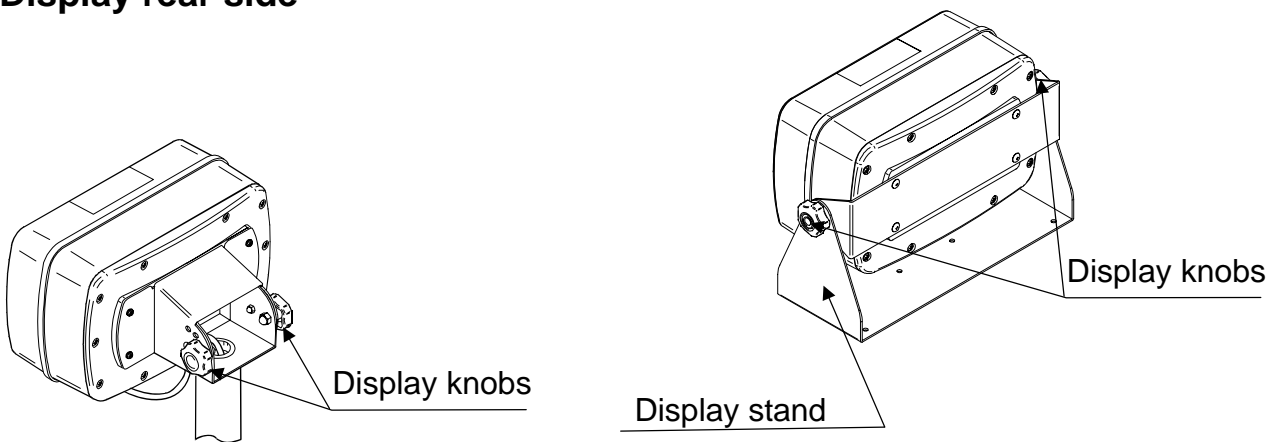

(The above illustration is for scales with a display pole.)

(The above illustration is for scales with a display stand.)

## 6.1. Display and symbols

### Display

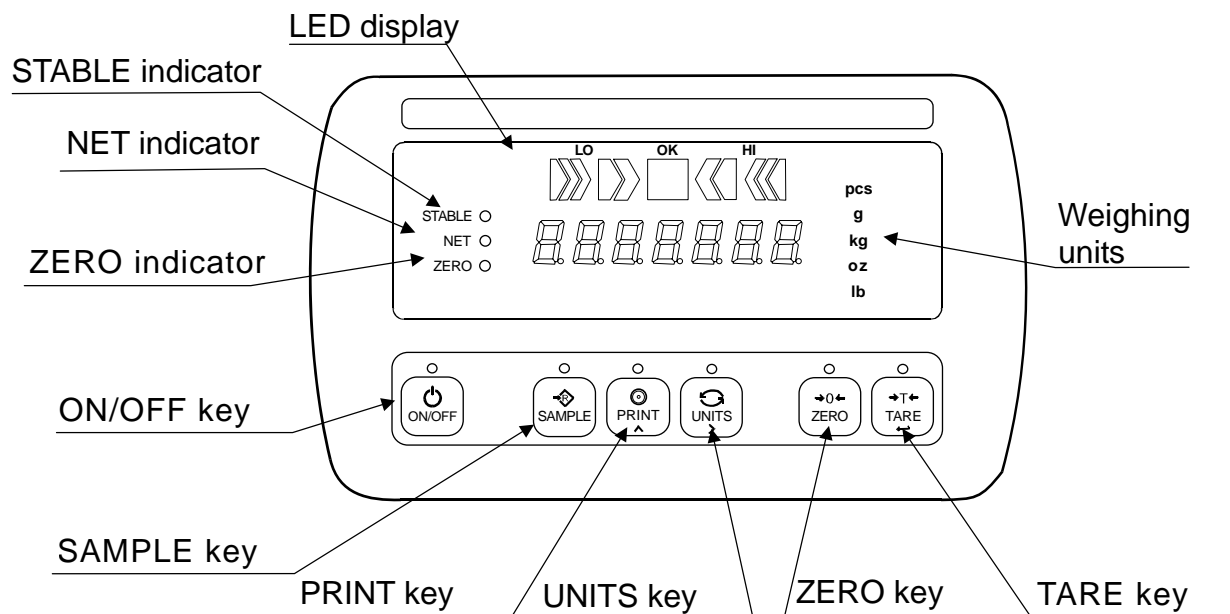





### Symbols

Symbol	Description
STABLE ○	Turns on when the weight value is stable.
NET ○	Turns on when the NET weight is displayed. (The tare operation is in progress.)
ZERO ○	Turns on when zero is displayed.
»»»□«««	Turns on when the comparator results are displayed.
Weighing units	“pcs”, “g”, “kg”, “oz” and “lb” are available. A selected unit turns on.

## 6.2. Keys

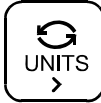
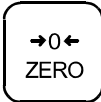
The keys are touch-sensitive. Three levels of key sensitivity are available and can be set in the function setting “ $\mu E Y$ ”. When set to “ $\mu E Y 2$ ” (High), the keys can be operated with a gloved finger.

Key	Description
	<u>ON/OFF key</u> Turns the power ON or OFF. When turned ON, the scale will be automatically set to zero (power-on zero). To turn the power OFF, press and hold the key. Note: If pressing the key does not turn the power ON immediately, keep pressing the key.
	<u>SAMPLE key</u> In the counting mode (“pcs”), goes to the unit weight storing mode. Press and hold to go to the comparator value setting mode.
	<u>PRINT key</u> Outputs the weight value to the printer. In the setting mode, this key is used to increase the value of the selected blinking digit by one.
	<u>UNITS key</u> Switches the weighing unit. In the setting mode, this key is used to shift the blinking digit to the right.
	<u>ZERO key</u> Zeroes the scale and sets the display to zero. (See below.)
	<u>TARE key</u> Subtracts the tare (container) weight placed on the weighing pan. (See below.) In the setting mode, this key is used to store the setting value and proceed to the next step.

- The **ZERO** key will zero the scale if the weight value is within  $\pm 2\%$  of the weighing capacity (kg) around the power-on zero point. The ZERO ● indicator turns on. (ZERO operation)
- The **ZERO** key functions while the weight value is stable.  
Even with “-E” displayed, when the STABLE indicator turns on, pressing the **ZERO** key will zero the scale.
- The **TARE** key will tare the scale and subtract the weight to zero as a tare weight when the weight is a positive stable value. In this case the ZERO ● and NET ● indicators turn on. (TARE operation)  
When the tare is removed while the tare operation is in progress and the scale returns to the zero point, the ZERO ● and NET ● indicators turn on. In this case the displayed tare value will be negative.  
**(Note: In some countries or areas, the ZERO ● indicator will not turn on during the TARE operation.)**
- When the tare is removed while the TARE operation is in progress and the ZERO operation described above is performed, the tare operation previously done is cleared and the NET ● indicator turns off.  
**(Note: In some countries or areas, after the ZERO operation, the TARE operation will not be cleared without pressing the **TARE** key.)**

# 7. SETTING UP

## 7.1. Attaching the display pole to the base

### SW-M / L series with a display pole

1. Remove the weighing pan from the base.
2. Remove the 4 screws from the lower part of the display pole.
3. Insert the display pole under the base while pulling out the cable into the base and align the cable opening positions of the pole and the base. (See "3" in the illustration.)
- ❑ **Do not pull the cable forcibly. Take care not to pinch the cable between the pole and the base.**
4. Align the screw holes of the pole and the base. Using the 4 screws removed at step 2 to secure the display pole to the base firmly.

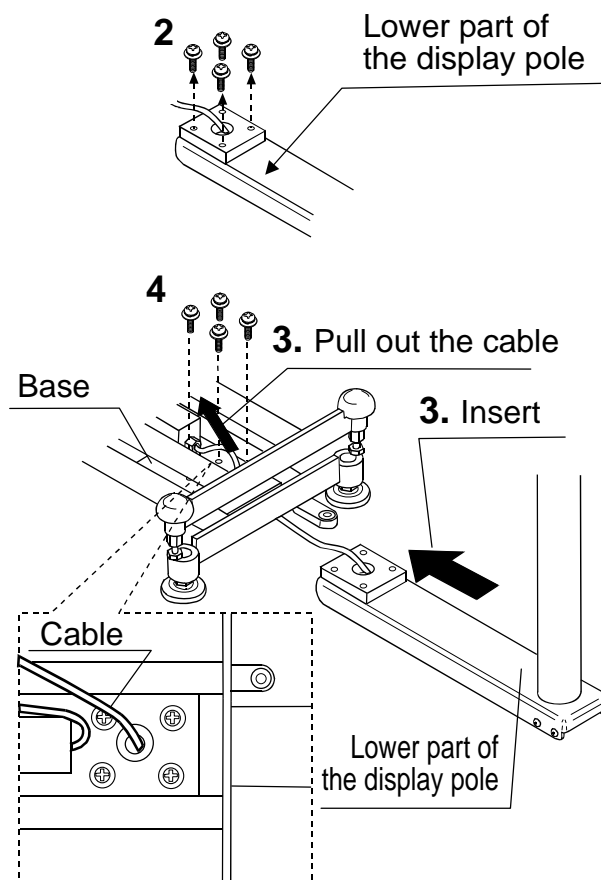

5. Lay the base on its side. Remove the 4 screws ("5" in the illustration) and remove the pole support foot.

6. Pull the excess cable out of the base. (See "6" in the illustration.)

- ❑ **Take care not to damage the cable. And make sure the cable has no slack.**

7. Pull the cable out to the pole side. (See "7" in the illustration.)

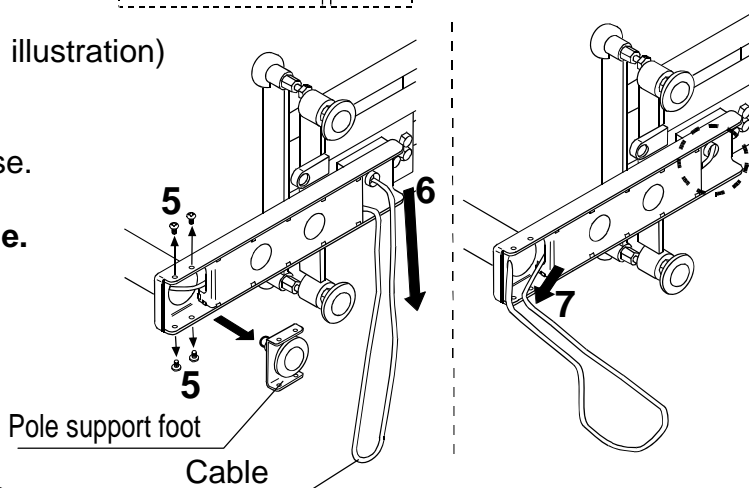

8. Put the bundle of cable back into the display pole. (See "8" in the illustration.)

9. Using the 4 screws removed at step 5, secure the pole support foot to the display pole.

10. Return the base to the upright position and place the weighing pan on the base.

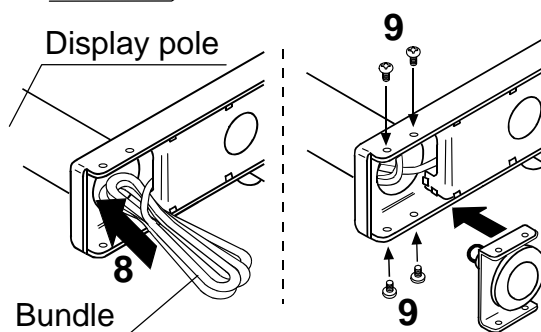

## 7.2. Installing the scale

1. Select the place for installing the scale.  
Refer to "4. PRECAUTIONS".
2. Adjust the level of the base, using the spirit level and leveling feet. Confirm that the bubble is in the center of the level.  
SW type with a display pole has an extra foot at the bottom of the pole. Adjust this foot to touch the floor after adjusting the level of the base.

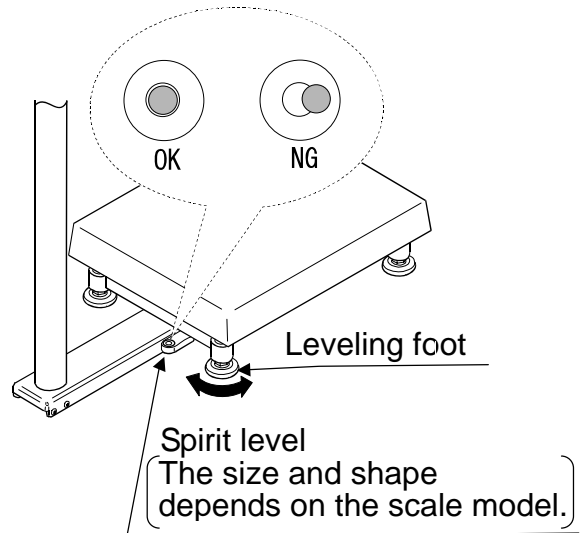

3. Adjust the display angle as follows.

### Type with a display pole

- (1) Rotate the two display knobs located on the display rear to remove them.
- (2) Tilt the display to an appropriate angle, 0°, 30°, 60° or 90°.
- (3) Attach the two display knobs and secure them firmly.

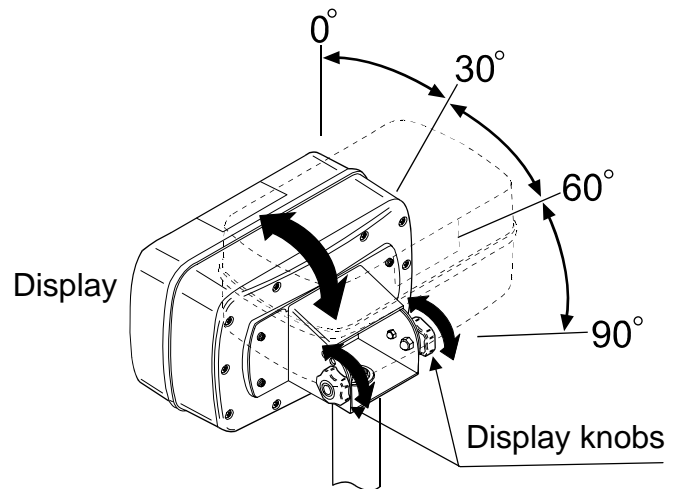

### Type with a display stand

- (1) Loosen the two display knobs located on the sides of the display.
- (2) Tilt the display to an appropriate angle. (Free setting angle)
- (3) Tighten the two display knobs.

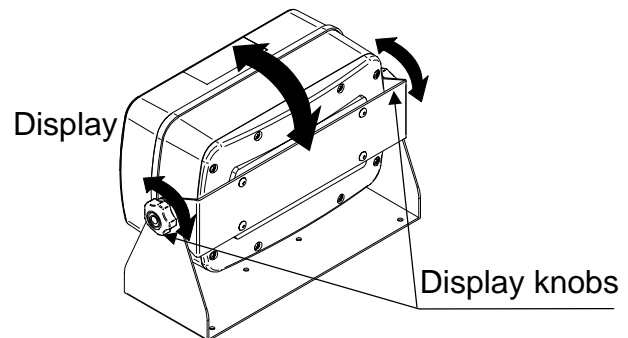

4. Confirm that nothing is touching the keys and connect the AC power cable to an electrical outlet.

### **⚠ DANGER**

- **The base frame is connected to the power GND (EXC-) inside the load cell. Be sure to earth ground the AC power cable. When the AC electrical outlet has no ground terminal, use the ground terminal (screw with the ground symbol) on the scale.**

**Location of the ground terminal**

**Models with a display pole: lower part of the display pole**

**Models with no display pole: bottom of the weighing pan**

---

## 8. BASIC OPERATION

---

### 8.1. Turning the power ON and OFF

1. Press the **ON/OFF** key to turn the power ON.

All the display symbols appear and the scale waits for the weight value to become stable.

When the optional sealed lead acid (SLA) battery (HC-02i) is used:

After all the display symbols appear, the battery capacity status is displayed for about 1.5 seconds as shown below.

Level	Display	Battery capacity status
1	"bAt 000"	Full capacity
2	"bAt _00"	
3	"bAt --0"	
4	"bAt ---"	No capacity (Low battery)

At level 3, prepare to recharge the battery.

At level 4, recharge the battery immediately. (Refer to "14.1. Using the HC-02i battery".)

After the weight value internally becomes stable, the display turns off for a moment, and then, zero is displayed along with the ZERO indicator (power-on zero).

If the weight value is unstable, "-----" is displayed. Check if anything touches the weighing pan, or if there is a strong draft or vibration. Eliminate the cause of the error.

The range for power-on zero is within  $\pm 50\%$  (within  $\pm 10\%$  for the Legal for Trade models) of the weighing capacity (kg) around the calibrated zero point.

If the power is turned ON while there is a load beyond this range, "-----" is displayed. Remove the load from the weighing pan.

- If the scale is to be turned ON with some item loaded, performing a zero calibration with the item loaded will allow the scale to turn ON that way. (Refer to "12. CALIBRATION".) In this case, make sure that the total weight of the item loaded at power-on and the object to be weighed is within the weighing capacity.

2. Press and hold the **ON/OFF** key to turn the power OFF.

- Auto power-off function

The auto power-off function automatically turns the power OFF, if zero is displayed for approximately 5 minutes.

Refer to "13.3. Function list" to set "POFF".

## 8.2. Selecting a weighing unit

In the weighing mode, press the **UNITS** key to select a weighing unit. Each time the **UNITS** key is pressed, the unit changes as shown below.

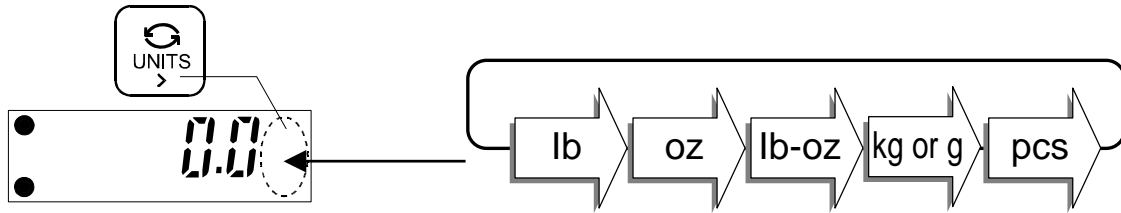

Using the function setting “**U<sub>t</sub>-G**”, “kg” and “g” can be switched.

**U<sub>t</sub>-G 0** : To display “kg”.

**U<sub>t</sub>-G 1** : To display “g”.

### Notes

- For the SW-60K / 150K, the function setting “**U<sub>t</sub>-G**” is not available and only “kg” is displayed.
- Not all the units are available, depending on the area or country.

## 8.3. Basic weighing operation

1. Press the **ON/OFF** key to turn the power ON. The unit used last before turning off appears.
2. Select a weighing unit using the **UNITS** key.
3. When the display doesn't show zero, press the **ZERO** key to set the display to zero.
4. When using a tare (container), place the container on the weighing pan, and press the **TARE** key to set the display to zero.
5. Place the object to be weighed on the weighing pan or in the container, and wait for the STABLE indicator to turn on and read the value.
6. Remove the object from the weighing pan.

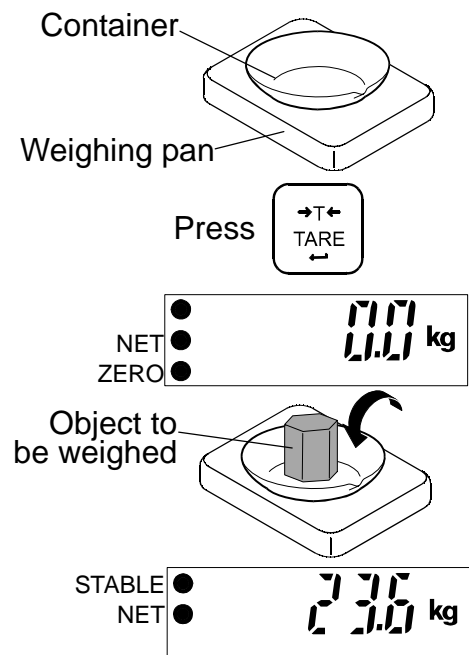

- ❑ The **ZERO** key will zero the scale if the weight value is within  $\pm 2\%$  of the weighing capacity (kg) around the power-on zero point. The ZERO ● indicator turns on.
- ❑ The **TARE** key will tare the scale and subtract the weight to zero as a tare weight when the weight is a positive value. The NET ● and ZERO ● indicators turn on.

**(Note: In some countries or areas, the ZERO ● indicator will not turn on during the TARE operation.)**

- ❑ Weighing is possible up to the weighing capacity. When a tare is used, weighing is possible up to the weighing capacity less the tare weight value.
- ❑ The **ZERO** and **TARE** keys function only when the weight values are stable.

## 8.4. Weight display resolution

The weight display resolution is a ratio of the minimum display to the weighing capacity. The SW series has three types of weight display resolution, as shown below.

Normal:	1/3,000
High:	1/6,000 or 1/7,500 (depending on the weighing capacity)
Maximum:	1/12,000 or 1/15,000 (depending on the weighing capacity)

The factory setting is the high resolution. Select the resolution that suits your own application in the function setting “rE50”.

- For details about the minimum display and the weighing capacity, refer to “16.1. Specifications”.
- The weight display resolution of the Legal for Trade models is fixed. The selection in the function setting “rE50” is not available.
- In the counting mode, the scale works with the maximum resolution regardless of the weight display resolution selected in the function setting “rE50”.



# 9. COUNTING MODE

Determines a unit weight (the weight of one piece) from a known sample quantity, and calculates how many pieces are on the weighing pan using the unit weight. The unit weight is maintained even if the power is turned OFF.

1. Press the **UNITS** key to select "pcs".  
("pcs" = pieces)

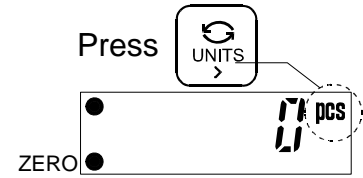

2. Press the **SAMPLE** key to enter the sample unit weight storing mode. The numerical value on the left indicates the number of samples.

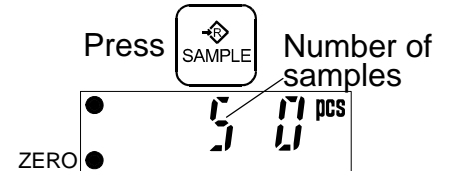

3. To change the number of samples, press the **PRINT** key. It may be set to 5, 10, 20, 50 or 100.

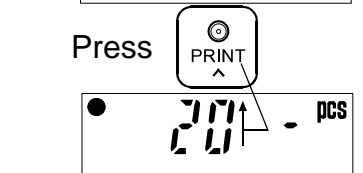

4. When "-" appears at the right side of the number of samples, press the **ZERO** key to zero the scale.

If necessary, place a container on the weighing pan, and press the **TARE** key. Confirm that the right side of the number of samples shows zero.

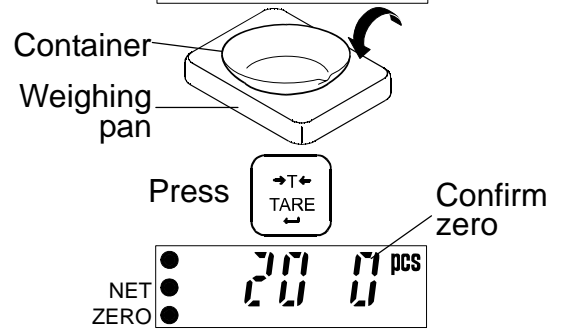

5. Place the correct number of samples on the weighing pan or in the container.

6. Confirm that the STABLE indicator is turned on. Press the **SAMPLE** key to calculate and store the unit weight. Remove the samples. The scale is set to count objects with this unit weight.

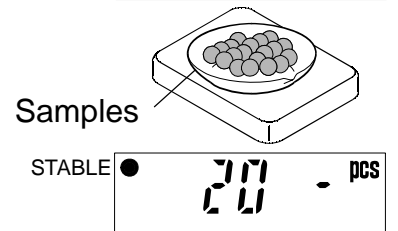

☐ The total weight of samples should be more than shown below, regardless of the number of samples.

- Weighing capacity of 6 kg: 0.005 kg
- Weighing capacity of 15 kg: 0.01 kg
- Weighing capacity of 30 kg: 0.02 kg
- Weighing capacity of 60 kg: 0.05 kg
- Weighing capacity of 150 kg: 0.1 kg

If not, the display shows "Lo ut" and returns to the display of step 5. Increase the number of samples (step 3) and try again.

☐ If the **SAMPLE** key is pressed before the weight above is reached, the scale exits the sample unit weight storing mode and returns to the counting mode display.

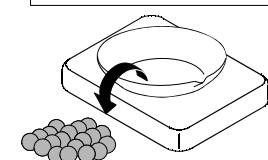

7. Place the objects to be counted on the weighing pan.

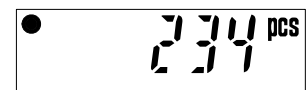

# 10. COMPARATOR

Five-level, three-level and seven-level (portion weighing mode) comparators are available.

Each comparator mode compares the weight value against the preset limit values and outputs the results using LEDs (yellow / green / red).

When the optional comparator relay output (SW-03) is installed, the results are output as a relay signal.

- Five-level comparator mode:

Uses four comparator values to compare the weight value and outputs results in five levels of LOLO, LO, OK, HI and HIHI.

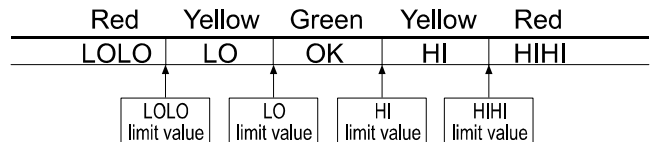

- Three-level comparator mode:

Uses two comparator values (upper and lower limit values) to compare the weight value and outputs results in three levels of LO, OK and HI.

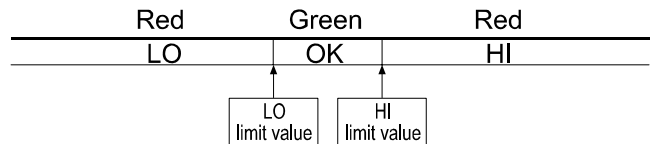

- Seven-level comparator mode (portion weighing mode):

Uses six comparator values to compare the weight value and outputs results in seven levels of over in the negative value, level 1 (LOLO), level 2 (LO), Level 3 (OK), level 4 (HI), level 5 (HIHI) and over in the positive value.

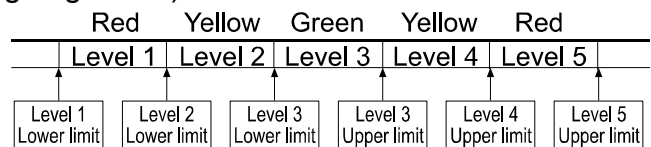

To use the comparator modes, the function settings “[P-L]” and “[P]” must be specified and the comparator values must be set.

Using the function setting “[P-L]”, select a comparator mode.

0: five-level comparator mode

1: three-level comparator mode

2: Seven-level comparator mode (portion weighing mode)

Using the function setting “[P]”, select comparison conditions.

0: No comparison (comparator mode disabled).

1: To compare all data.

2: To compare all stable data.

3: To compare all data which are more than or equal to +5d, or less than or equal to -5d.

4: To compare stable data which are more than or equal to +5d, or less than or equal to -5d.

5: To compare all data which are more than or equal to +5d.

6: To compare stable data which are more than or equal to +5d.

d = minimum display in kg (Refer to “16.1. Specifications”).

Also in the counting mode, “d” is equal to the minimum display of kg mode.

## 10.1. The formula to compare

Comparison is performed using the formula listed below and the results are output.

### Five-level comparator mode

Results	Comparison formula	LED display
LOLO	Displayed value < LOLO limit value (Or over in the negative value)	■▷□□□ ( Red LED on)
LO	Displayed value < LO limit value	▷■□□□ ( Yellow LED on)
OK	LO limit value ≤ Displayed value ≤ HI limit value	▷▷■□□ ( Green LED on)
HI	HI limit value < Displayed value	▷▷□■□ ( Yellow LED on)
HIHI	HIHI limit value < Displayed value (Or over in the positive value)	▷▷□□■ ( Red LED on)

### Three-level comparator mode

Results	Comparison formula	LED display
LO	Displayed value < LO limit value (Or over in the negative value)	■▷□□□ ( Red LED on)
OK	LO limit value ≤ Displayed value ≤ HI limit value	▷▷■□□ ( Green LED on)
HI	HI limit value < Displayed value (Or over in the positive value)	▷▷□□■ ( Red LED on)

### Seven-level comparator mode (portion weighing mode)

Results	Comparison formula	LED display
None	Displayed value < Level 1 lower limit value (Or over in the negative value)	▷▷□□□ ( No LEDs on)
LOLO (Level 1)	Displayed value < Level 2 lower limit value	■▷□□□ ( Red LED on)
LO (Level 2)	Displayed value < Level 3 lower limit value	▷■□□□ ( Yellow LED on)
OK (Level 3)	Level 3 lower limit value ≤ Displayed value ≤ Level 3 upper limit value	▷▷■□□ ( Green LED on)
HI (Level 4)	Level 3 upper limit value < Displayed value	▷▷□■□ ( Yellow LED on)
HIHI (Level 5)	Level 4 upper limit value < Displayed value	▷▷□□■ ( Red LED on)
None	Level 5 upper limit value < Displayed value (Or over in the positive value)	▷▷□□□ ( No LEDs on)

- The comparator values are common to the weighing and counting mode.
- Ignore the decimal point when setting the comparator values.  
For example, when the weighing capacity is 6 kg and the setting value is "001000":

Display mode	Limit value	Capacity / Minimum display
Normal resolution kg	1.000 kg	6.000 kg / 0.002 kg
High resolution kg	1.000 kg	6.000 kg / 0.001 kg
Maximum resolution kg	0.1000 kg	6.0000 kg / 0.0005 kg
Normal resolution oz	100.0 oz	210.0 oz / 0.1 oz
High resolution oz	10.00 oz	210.00 oz / 0.05 oz
Maximum resolution oz	10.00 oz	210.00 oz / 0.02 oz
Counting mode	1000 pcs	

- The comparator values are maintained even if the power is turned OFF.
- Judgment order of comparison is from the top row to the bottom in the comparator mode tables
- The entered comparator values are not judged. Even if the upper limit value is less than the lower limit value, no error will be output.

## 10.2. Entering the comparator values

- In the weighing mode, press and hold the **SAMPLE** key to enter the comparator value setting mode.
- Enter the comparator values using the following keys.

- UNITS** To shift the blinking digit to the right.
- PRINT** To increase the value of the blinking digit by one.
- SAMPLE** To switch the polarity. Each time the key is pressed, “-” is turned on and off at the left-most digit. When on, the value is negative.
- TARE** To confirm and store the setting value.

- When the setting is complete, “*End*” is displayed and the scale returns to the weighing mode. (At this time, power-on-zero is not performed.)

### Five-level comparator mode

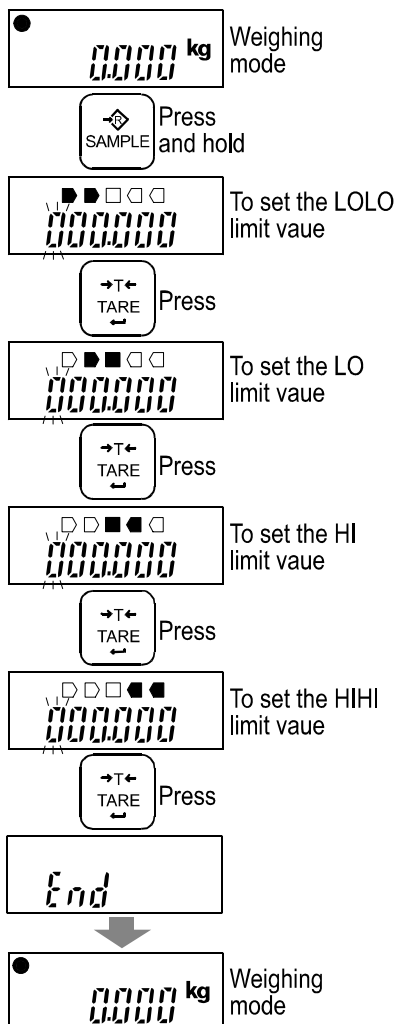

### Three-level comparator mode

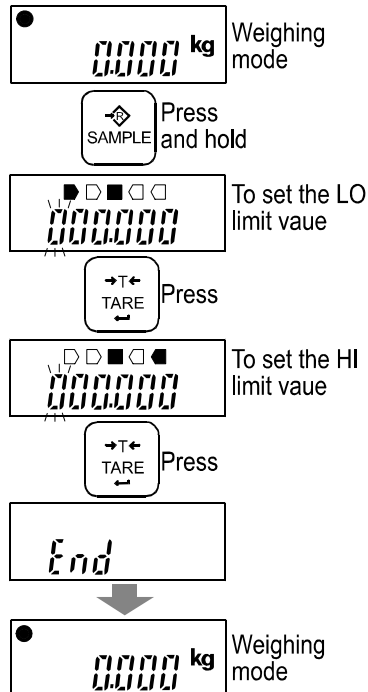

### Seven-level comparator mode

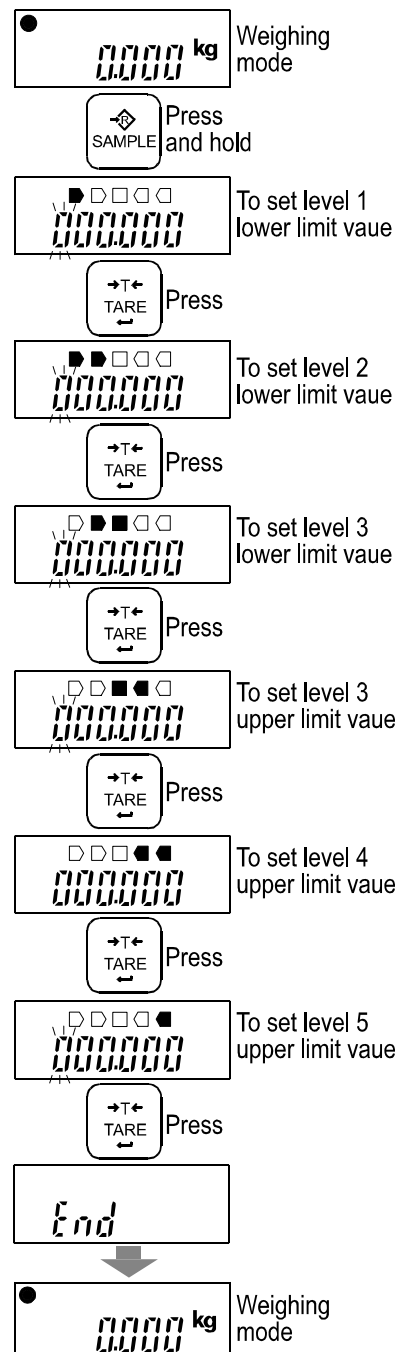

# 11. AUTO-TARE FUNCTION

The SW series has an auto-tare function to be used with the comparator mode enabled. Using this function in check weighing, the scale automatically tares, then displays “OK” for a certain amount of sample and repeats this process for the next weighing.

Start with display zero after tare operation. Place or take away objects until the comparison result will show OK. When the stable display is maintained for the duration specified in the function setting “*At-t*”, the scale will automatically tare the weight, show zero and be ready for next weighing.

- ❑ In some countries or areas, the auto-tare function can not be used on the Legal for Trade models and the selection in the function settings “*At*”, “*At-t*” and “*At-F*” is not available.

- ❑ To use the auto-tare function, set the function settings below.

*CP 1*: Compare all weighing data (other settings may be used depending on the application).

*At 1*: Auto-tare function enabled.

*At-t 0 ~ 9*: Select the timing to tare automatically to avoid the wrong tare operation, for example; too early to tare, to take a longer time to go to the next weighing.

- ❑ Take-away check weighing “*CP-P 1*” (Example with “*CP-L 0*” setting)

Take-away check weighing (negative comparison) is the way to compare the negative weight while taking away objects from a container.

Set the function “*CP-P 1*” together with the auto-tare function enabled “*At 1*”. In this operation mode, the scale operates as “take-away the objects” → “OK and stable” → “auto-tare” → “take-away the objects” → .....

In this setting, the polarity of LOLO, LO, HI, and HIHI limit values are ignored and the scale shows the comparator results as below.

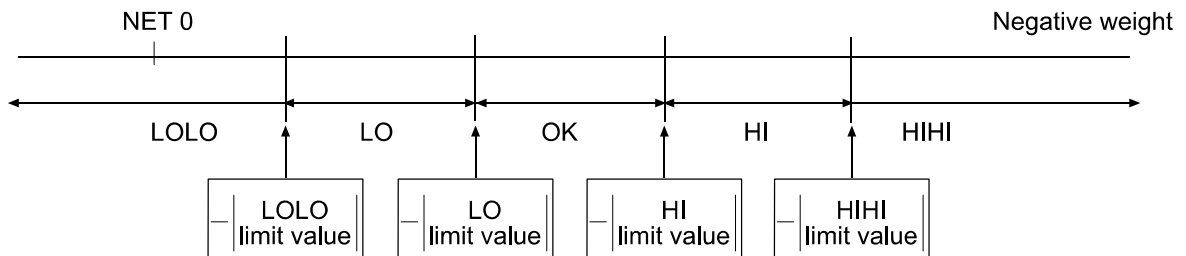

Note: To start the take-away check weighing, be sure to use the **TARE** key to tare the weight of the container filled with objects. The **ZERO** key may zero the display, and the scale goes below the zero point by taking out the objects. Then, the auto-tare function does not work.

- ❑ When the function “*At-F 1* Tares the initial (container) weight.” is selected:

To start the auto-tare function, usually the container (filled with objects) will be placed on the weighing pan and its weight must be tared using the **TARE** key. When the function “*At-F 1*” is selected, the scale will tare the initial (container) weight automatically.

When all load on the weighing pan is removed, the scale will return to the zero point and the tare weight will be automatically cleared. If the scale does not return to the zero point, press the **ZERO** key to clear the tare weight.

- ❑ If the scale is equipped with the optional RS-232C serial interface (SW-03) or optional RS-422/485 serial interface (SW-04), the OK weighing data only can be output automatically. Set the function setting “*Pr-t 5*”.

---

# 12. CALIBRATION

---

Adjusts the scale for accurate weighing.  
Calibrate the scale in the following cases.

- When the scale is first installed.
- When the scale has been moved.
- When the ambient environment has changed.
- For regular calibration.

**Note: Calibration can not be performed on the Legal for Trade models.**

## 12.1. Calibration mode

- The calibration mode has the following three functions.
  - Gravity acceleration correction
  - Calibration using a weight
  - Restoring the factory set values
- How to enter the calibration mode

### Method 1:

1. Make sure that the scale is in the weighing mode (displaying “kg” (“g”), “lb”, “oz” or “pcs”).
2. Press and hold the **TARE** key until the gravity acceleration value (in this example, “G 9.7985”) appears and release the key.

**Note: The above operation is disabled for the Legal for Trade models. The Legal for Trade models can not enter the calibration mode.**

### Method 2:

1. Make sure that the scale is in the weighing mode (displaying “kg” (“g”), “lb”, “oz” or “pcs”).
2. Remove the screw protection caps on the load cell panel on the bottom of the display. Loosen the four screws and then open the load cell panel. The calibration (CAL) switch is located inside.
3. Press the CAL switch. The scale displays the gravity acceleration value (in this example, “G 9.7985”).

**Note: The load cell panel for the Legal for Trade models has been sealed using wire locked screws. The CAL switch does not work on the Legal for Trade models.**

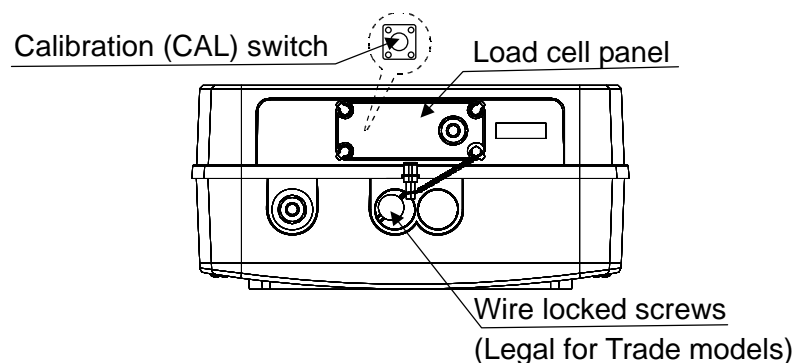

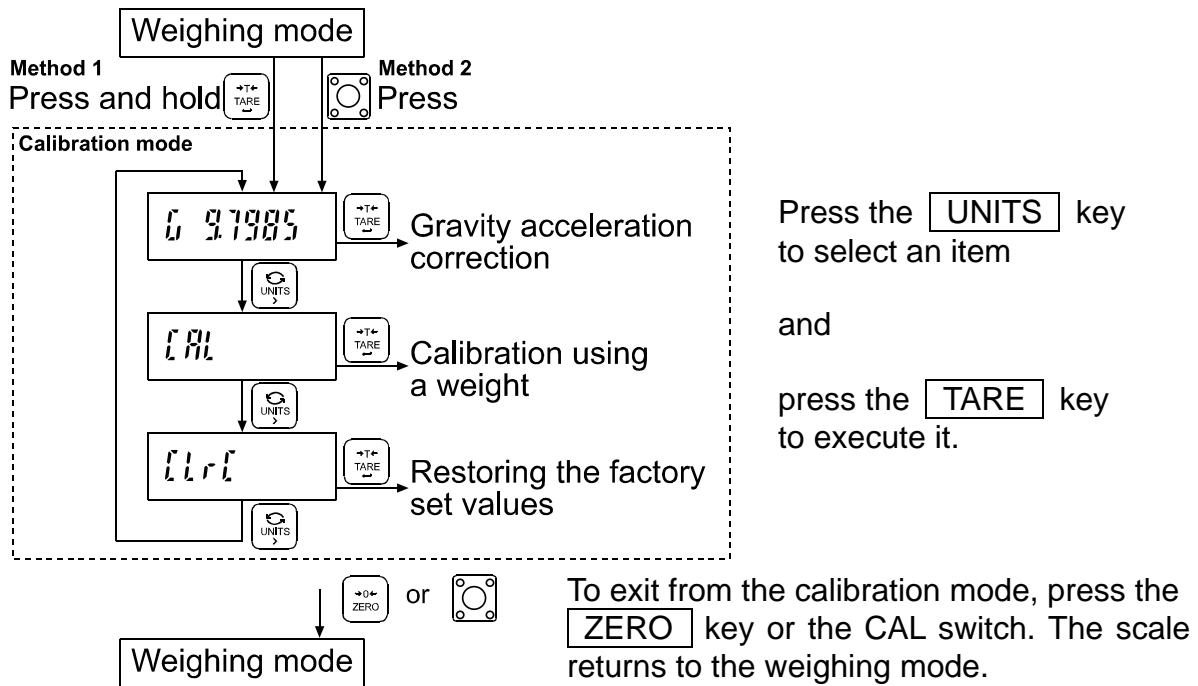

## 12.2. Gravity acceleration correction

When the scale is first used or has been moved to another location, it should be calibrated using a calibration weight.

But if a calibration weight is not available, the gravity acceleration correction will compensate the scale. Change the gravity acceleration value stored in the scale to the value of the area where the scale will be used. Refer to the gravity acceleration map at the end of this manual.

**Note: Gravity acceleration correction is not required when the scale will be calibrated using a calibration weight at the place where it is to be used.**

1. Refer to “12.1. Calibration mode” to enter the calibration mode. The gravity acceleration value is displayed.

2. Press the **TARE** key to enter the gravity acceleration value setting mode.

3. Change the displayed value using the following keys.

**UNITS** To shift the blinking digit to the right.

**PRINT** To increase the value of the blinking digit by one.

4. Press the **TARE** key. The setting value is stored and “End” is displayed.

5. When calibration using a calibration weight is to be performed, go to step 3 of “12.3. Calibration using a weight”.

To finish the setting procedure, press the **ZERO** key or the CAL switch. The scale returns to the weighing mode.

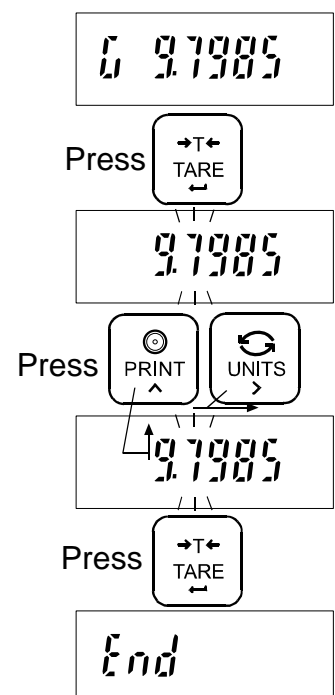

## 12.3. Calibration using a weight

Prepare a weight, preferably a weight with the same value as the weighing capacity of the scale to be calibrated. Note that the calibration weight value can be changed.

1. Turn the power ON and warm up the scale for at least half an hour.

Change the function setting “POFF” or place something on the weighing pan to disable the auto power-off function.

2. Refer to “12.1. Calibration mode” to enter the calibration mode. The gravity acceleration value is displayed.

3. Press the **UNITS** key and display “CAL”.

4. Press the **TARE** key until “CAL 0” is displayed. Confirm that nothing is placed on the weighing pan and wait for the STABLE indicator to turn on.

5. Press the **TARE** key. The scale calibrates the zero point and displays the value of the calibration weight (SPAN calibration).

The calibration weight value is equal to the weighing capacity. (factory setting)

When you enter with “kg” (“g”) or “pcs” mode, the value is in “kg”. With “lb” or “oz”, then “lb”.

If SPAN calibration is not to be performed, turn the power OFF to exit from the calibration procedure.

6. To calibrate with a weight different from the weighing capacity, change the displayed value using the following keys.

**UNITS** To shift the digit that is blinking to the right.

**PRINT** To increase the value of the blinking digit by one.

Using a weight with the same value as the weighing capacity is recommended. If other weights are used, use one with a value greater than two-thirds of the capacity.

7. Place the calibration weight with the same value as displayed on the weighing pan, and wait for the STABLE indicator to turn on.

8. Press the **TARE** key. The scale calibrates SPAN and “End” is displayed.

To finish the setting procedure, press the **ZERO** key or the CAL switch. The scale returns to the weighing mode.

**Note:** If the scale will be moved to another location, set the gravity acceleration value for the new location and calibrate the scale according to the procedure above. Refer to the previous section to set the gravity acceleration value.

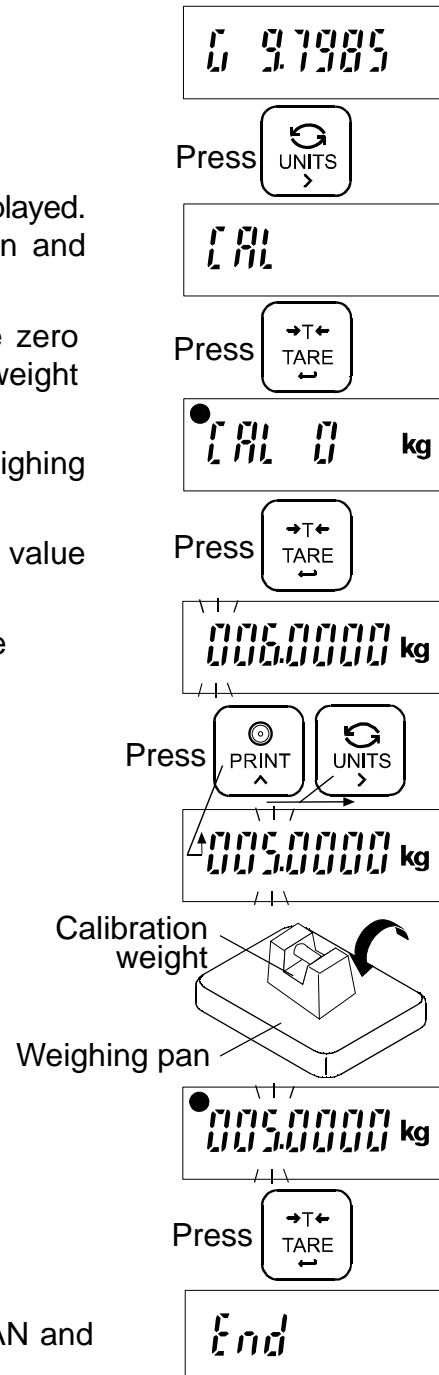



## 12.4. Restoring the factory set values

If the gravity acceleration value or calibration weight value is changed unintentionally, restore those values to the factory set values, as follows.

1. Refer to “12.1. Calibration mode” to enter the calibration mode. The gravity acceleration value is displayed.
2. Press the **UNITS** key twice to display “**[Lr[**” .
3. Press the **TARE** key to display “**[Lr[ no**” with “**no**” blinking.
4. Press the **PRINT** key.  
“**[Lr[ no**” changes to “**[Lr[ go**” with “**go**” blinking.
- To cancel the restoring procedure, press the **ZERO** key. The display returns to step 2.
5. When “**[Lr[ go**” is displayed, press the **TARE** key. The factory set values are restored and “**End**” is displayed.

To finish the setting procedure, press the **ZERO** key or the CAL switch. The scale returns to the weighing mode.

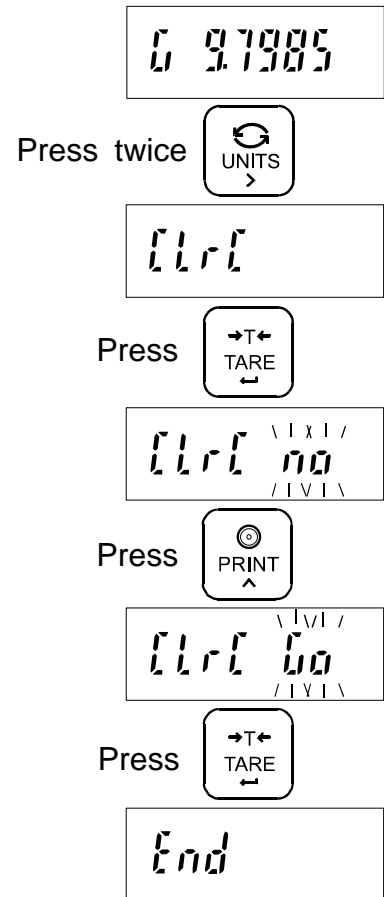

# 13. FUNCTIONS

The scale has function settings to specify the scale performance. The parameters set in the function settings are maintained even if the power is turned OFF.

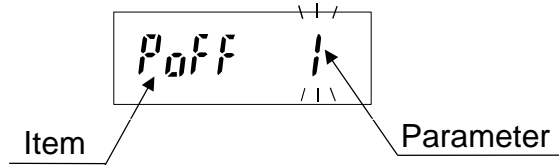

## 13.1. Setting the parameters

1. Turn the power OFF.
2. Press and hold the **TARE** key and press the **ON/OFF** key to turn the power ON. The software version is displayed.
  - ❑ “\*\*\*” indicates the software version number.
3. After about one second, the item is displayed.
4. Change the item or parameter using the following keys.
 

UNITS	To display the next item.
PRINT	To increase the value of the blinking digit by one (to change the parameter).

  - ❑ When the parameter is changed, the STABLE indicator turns off.
5. Press the **TARE** key to store the setting value. After “End”, the power is turned OFF automatically.
  - ❑ To cancel the setting procedure without storing the value, press the **ZERO** key. The power is turned OFF automatically.

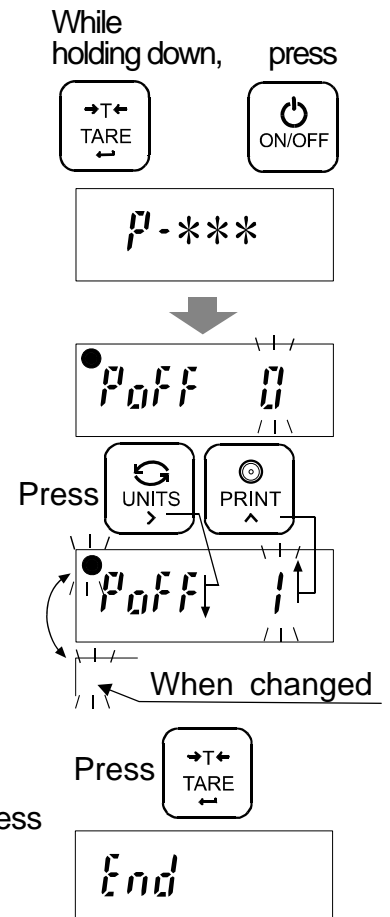

## 13.2. Restoring the function settings to the factory set values

1. Turn the power OFF.
2. Press and hold the **TARE** key and press the **ON/OFF** key to turn the power ON. Only release the **ON/OFF** key and hold the **TARE** key until “LrF no” with “no” blinking is displayed.
3. Press the **PRINT** key. “LrF no” changes to “LrF 00” with “00” blinking.
4. When “LrF 00” is displayed, press the **TARE** key. The factory set values are restored. After “End”, the power is turned OFF automatically.
  - ❑ To cancel the restoring procedure, press the **ZERO** key. The power is turned OFF automatically..

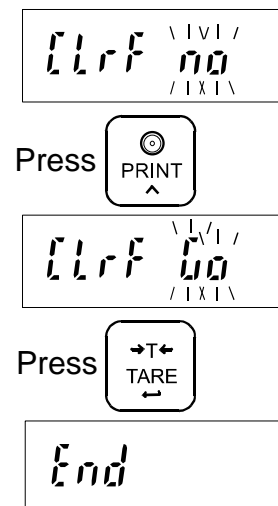

### 13.3. Function list

Item	Parameter	Description	
Auto power-off function <i>P<sub>OFF</sub></i>	◆ 0	Auto power-off disabled	Turns the power OFF automatically
	1	Auto power-off enabled	
Weight display resolution <i>rESD (See Note)</i>	0	Normal (1/3,000)	Changes the minimum display
	◆ 1	High (1/6,000 or 1/7,500)	
	2	Maximum (1/12,000 or 1/15,000)	
Weighing unit <i>U<sub>U</sub>-G</i>	◆ 0	kg	
	1	g	
Zero tracking <i>t<sub>rc</sub></i>	0	Zero tracking function disabled	Tracks the zero drift
	◆ 1	Zero tracking function enabled	
Stability band width <i>St-b (See Note)</i>	◆ 0	±0.5d (width 1d)	Conditions to turn the STABLE indicator on
	1	±1.0d (width 2d)	
	2	±2.0d (width 4d)	
Stability detection time <i>St-t</i>	0	0.5 second	d = minimum display in kg
	◆ 1	1.0 second	
	2	2.0 seconds	
Stability Response speed <i>Cond</i>	◆ 0	Weak stability / fast response	Filtering. Factory setting for models of weighing capacity 60 and 150 kg is 1.
	1	Normal stability / normal response	
	2	Strong stability / slow response	
Serial interface baud rate <i>bPS</i>	◆ 0	2400 bps	Only when the options, RS-232C or RS-422/485, are used.
	1	4800 bps	
	2	9600 bps	
Serial interface data bits / parity <i>b<sub>tPr</sub></i>	◆ 0	7 bits / EVEN	
	1	7 bits / ODD	
	2	8 bits / Non parity	
Serial interface Data output mode <i>Pr<sub>t</sub></i>	◆ 0	Stream mode / Command mode	
	1	Command mode only	
	2	Print key mode / Command mode	
	3	Auto-print mode +/- data / Command mode	
	4	Auto-print mode + data/ Command mode	
	5	Auto-print mode +/- data and OK / Command mode	
Serial interface Type <i>S<sub>iF</sub></i>	◆ 0	RS-232C	
	1	RS-422	
	2	RS-485	
Serial interface Address <i>Adr</i>	##	## = 00 to 99 (Factory setting: ## = 01)	

Item	Parameter	Description	
Serial interface Response <i>RLP</i>	0	No reply except data to commands	Only when the options, RS-232C or RS-422/485, are used.
	♦ 1	Reply to commands	
Comparator mode <i>CP-L</i>	♦ 0	Five-level	
	1	Three-level	
	2	Seven-level (portion weighing mode)	
Comparison conditions <i>CP</i>	♦ 0	Comparator disabled	Sets comparison conditions  d = minimum display in kg
	1	Compares all data	
	2	Compares all stable data	
	3	Compares all data of $\geq +5d$ or $\leq -5d$	
	4	Compares stable data of $\geq +5d$ or $\leq -5d$	
	5	Compares data of $\geq +5d$	
Key sensitivity <i>PEY</i>	0	Low	
	♦ 1	Medium	
	2	High	
Auto-tare function <i>RL</i> (See Note)	♦ 0	Auto-tare function disabled	Refer to “11. AUTO-TARE FUNCTION”
	1	Auto-tare function enabled	
Auto-tare timing <i>RL-t</i> (See Note)	0	Immediately after OK and stable	Timing to tare automatically after the comparison OK and stable weight. To be used with “ <i>RL 1</i> ”.
	1	0.5 second after OK and stable	
	♦ 2	1.0 second after OK and stable	
	3	1.5 seconds after OK and stable	
	4	2.0 seconds after OK and stable	
	5	2.5 seconds after OK and stable	
	6	3.0 seconds after OK and stable	
	7	4.0 seconds after OK and stable	
	8	5.0 seconds after OK and stable	
Auto-tare for the initial weight <i>RL-F</i> (See Note)	♦ 0	Function disabled	Automatic operation
	1	Tares the initial (container) weight.	
Normal/Negative comparison <i>CP-P</i>	♦ 0	Normal comparison	Refer to “11. AUTO-TARE FUNCTION”
	1	Negative comparison for take-away check weighing	

♦ Factory setting

d = minimum display in kg, the minimum mass that can be weighed in kg  
Even the counting mode uses “d” for judgment.

**(Note: In some countries or areas, “*rES0*”, “*St-b*”, “*RL*”, “*RL-t*” and “*RL-F*” are not available for the Legal for Trade models.)**

---

# 14. OPTIONS

---

## 14.1. Using the HC-02i battery

- ❑ The scale can be operated with a sealed lead acid (SLA) battery, available as an option.
- ❑ The scale (with no other options) can be operated continuously for about 90 hours with a fully charged battery.
- ❑ The battery will take about 15 hours to be fully charged.
- ❑ The battery life will vary depending on how the scale is used, the ambient temperature and so on.
- ❑ A battery, NP4-6 (6V, 4Ah), manufactured by YUASA, is commercially available.

### Caution

- There will be risk of leakage, fire or explosion if the battery is connected improperly or replaced with the incorrect type.
- Dispose of a used battery according to the local laws and regulations.
- Do not handle the battery with wet hands. Take much care not to get the battery wet.
- Do not install the battery under high temperatures and high humidity.
- Even when the battery is used, be sure to prevent the AC plug from getting wet.

### 14.1.1. Installing the battery

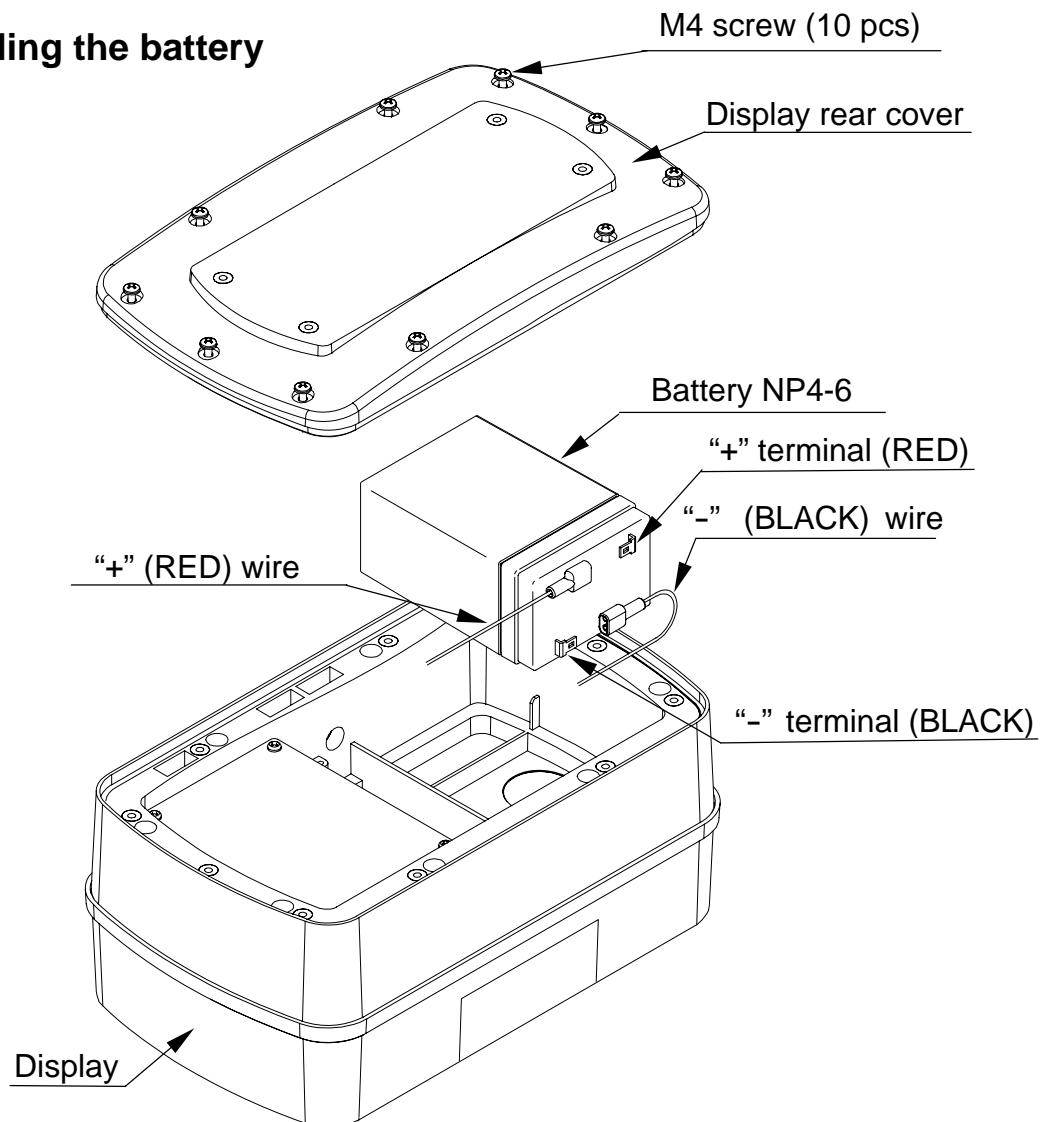

1. Disconnect the AC power cable from the electrical outlet.
2. Loosen the M4 screws and remove the rear cover of the display.  
**Note: Take care not to drop the display.**
3. Connect the wires inside the display to the battery with much care so that nothing touches the keys.  
**Note: Be sure to connect the RED wire to the positive (+ / RED) terminal and the BLACK wire to the negative (- / BLACK) terminal. Or there is a risk of explosion.**
4. Install the battery into the display.
5. Attach the rear cover to the display and secure it with the screws loosened at step 2.
6. Connect the AC power cable to the electrical outlet.
7. Press the ON/OFF key and check that the scale turns ON.
8. Disconnect the AC power cable and check that the scale works normally.

#### 14.1.2. Charging the battery

- When the display shows “*l b*” (Low battery), the battery voltage is low and should be recharged. Turn the scale OFF and connect the AC power cable to an electrical outlet. The charging process will start.
- Charging will be performed when the AC power cable is connected to an electrical outlet and the scale is turned OFF. If the scale is turned ON, trickle charging will be performed.
- The scale can be used while the battery is charging. After fully charged, the scale will change the charging process to trickle charge automatically.

#### Notes

- Charge the battery at a temperature between 0°C (32°F) and 40°C (104°F), preferably, at a range of 5°C (41°F) to 35°C (95°F) .
- Charge the battery when using for the first time.
- The battery must be recharged regularly, every 3 to 6 months, if the scale is not used for a long period of time. More frequent recharging is required in a warmer area.

## 14.2. SW-03 RS-232C / RELAY OUTPUT

This interface allows the SW scale to be connected to an AD-8121 printer or a personal computer, and the relay outputs for comparator results are also available.

- ❑ When SW-03 is installed, the dust-tight and water-tight performance of the scale will be degraded.
- ❑ SW-03 includes an interface board, two connector cables (7 and 10 pins), two cable glands (for cable diameter 3.5 to 7.0 mm) and two screws (M3x8).

### 14.2.1. Installing SW-03

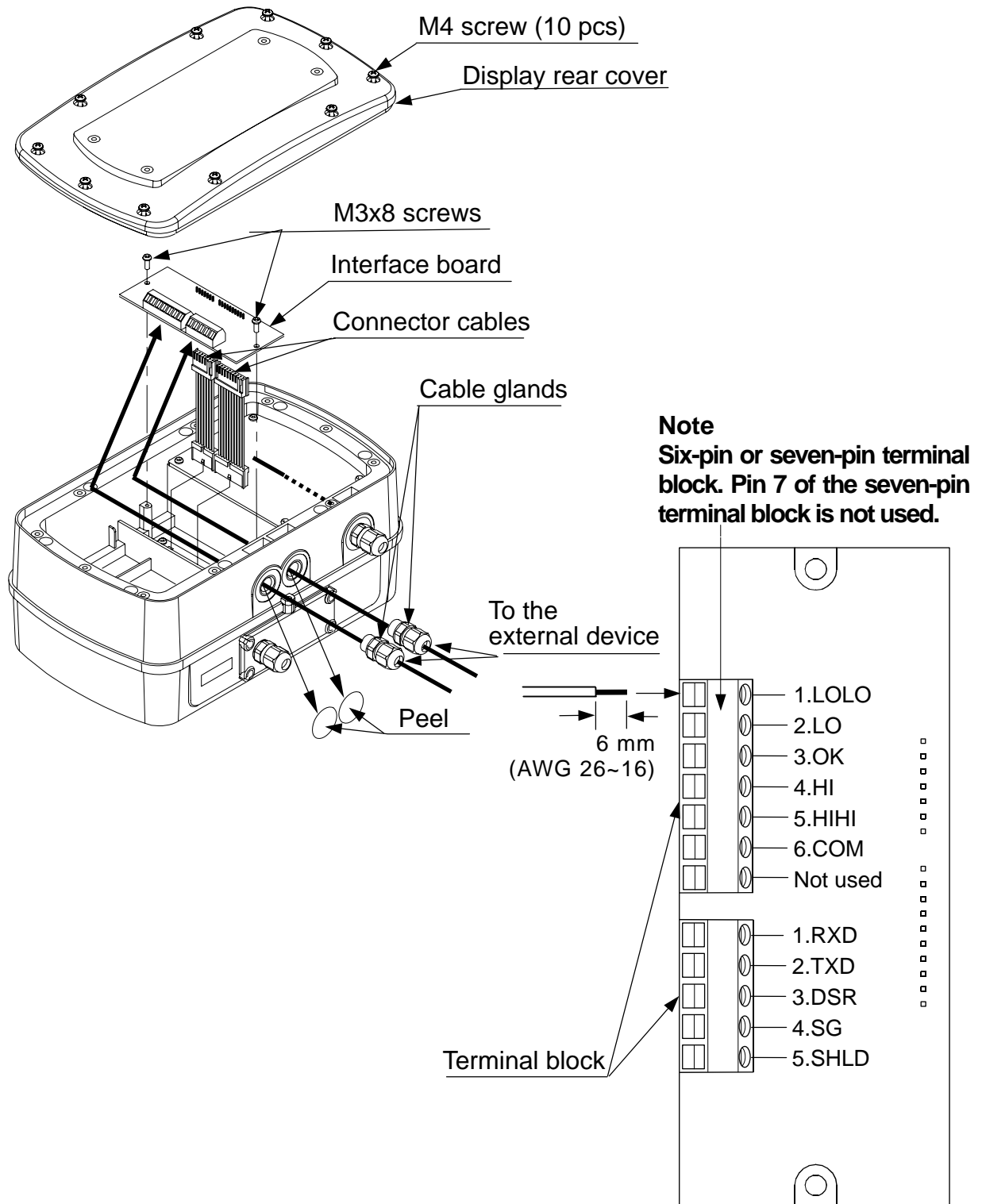

1. Disconnect the AC power cable from the electrical outlet. When the battery is installed, make sure that the scale is turned OFF.
2. Loosen the M4 screws and remove the rear cover of the display.
 

**Note: Take care not to drop the display.**
3. Connect the cables to the external device through the cable gland to the terminal blocks on the interface board.
4. Attach the connector cables (7 and 10 pins), provided with SW-03, to the connectors on the interface board and the connectors on the main board inside the display.
5. Secure the interface board using the two M3 x 8 screws provided with SW-03.
6. Tighten the cable glands and attach the rear cover to the display and secure it with the screws loosened at step 2.
7. Connect the AC power cable to the electrical outlet.
8. Set the function setting “*SIF*” to “*0*”.  
And set the function settings “*bPS*”, “*bLPr*”, “*PrL*” and “*ACL*” as necessary.

RS-232C cables, for connecting the SW-03 interface board with external devices, are available as options that are sold separately.

- AX-KO3285-320 --- Optional cable unit for connection with a personal computer (3 m)
- AX-KO3341-320 --- Optional cable unit for connection with an AD-8121B printer (3 m)

Refer to the following to use these cables.

## Preparation

### AX-KO3285-320

- (1) Remove about 6 mm from the end of the black heat shrink tubing and 6 mm of insulation from the end of the red, black, green and blue wires.
- (2) Apply electrical tape to each of the other wires to avoid short circuits.

### AX-KO3341-320

- (1) Remove about 6 mm of insulation from the end of the orange and purple wires.
- (2) Apply electrical tape to each of the other wires to avoid short circuits.

## Connection

Connect wires to the RS-232C terminal block of the SW-03 interface board as listed below.

AX-KO3285-320: To a personal computer

SW-03 terminal block		Cable
1. RXD	---	Black (Pin 3)
2. TXD	---	Red (Pin 2)
3. DSR	---	Blue (Pin 6)
4. SG	---	Green (Pin 5)
5. SHLD	---	Black heat shrink tubing-covered wire

AX-KO3341-320: To a printer

SW-03 terminal block		Cable
1. RXD		
2. TXD	---	Orange (Pin 3)
3. DSR		
4. SG	---	Purple (Pin 7)
5. SHLD		



❑ When connecting to an external device with hardware flow control, communication will be impossible using a cable without RTS and CTS connected. In that case, connect RTS and CTS. This will disable hardware flow control, but will enable communication.

- When the connector of an external device is a D-Sub 9-pin connector, pin 7 is RTS and pin 8 is CTS.
- When the AX-KO3285-320 cable is used, RTS and CTS are internally connected and the above operation is unnecessary.

### 14.2.2. SW-03 specifications

#### RS-232C interface

Transmission form	Asynchronous, bi-directional, half-duplex
Data format	Baud rate: 2400, 4800, 9600 bps
	Data bits: 7 bits + parity 1bit (EVEN / ODD) or 8 bits (non parity)
	Start bit: 1 bit
	Stop bit: 1 bit
	Code: ASCII
	Terminator: C <sub>R</sub> L <sub>F</sub> (C <sub>R</sub> :0Dh, L <sub>F</sub> :0Ah)

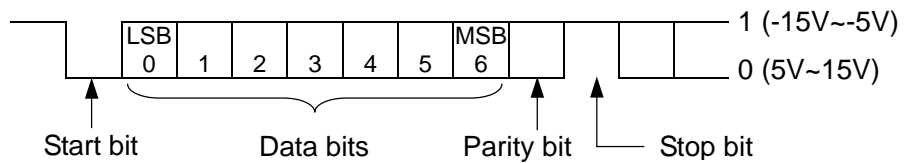

#### Relay output

The maximum rating of the replay output is as follows.

- ❑ Maximum voltage: 50V DC
- ❑ Maximum current: 100 mA DC
- ❑ Maximum ON resistance: 8 Ω

Circuit diagram

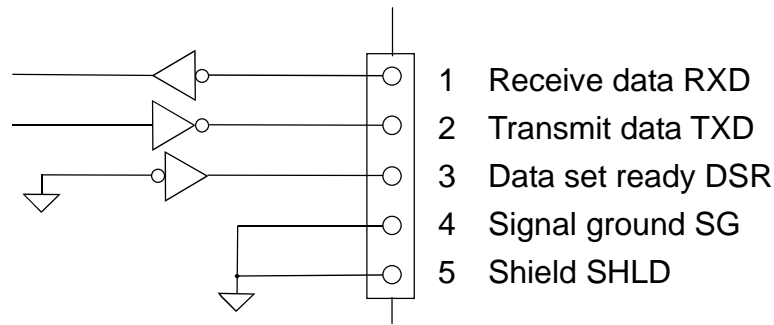

❑ SW is designed as DCE (Data Communication Equipment).

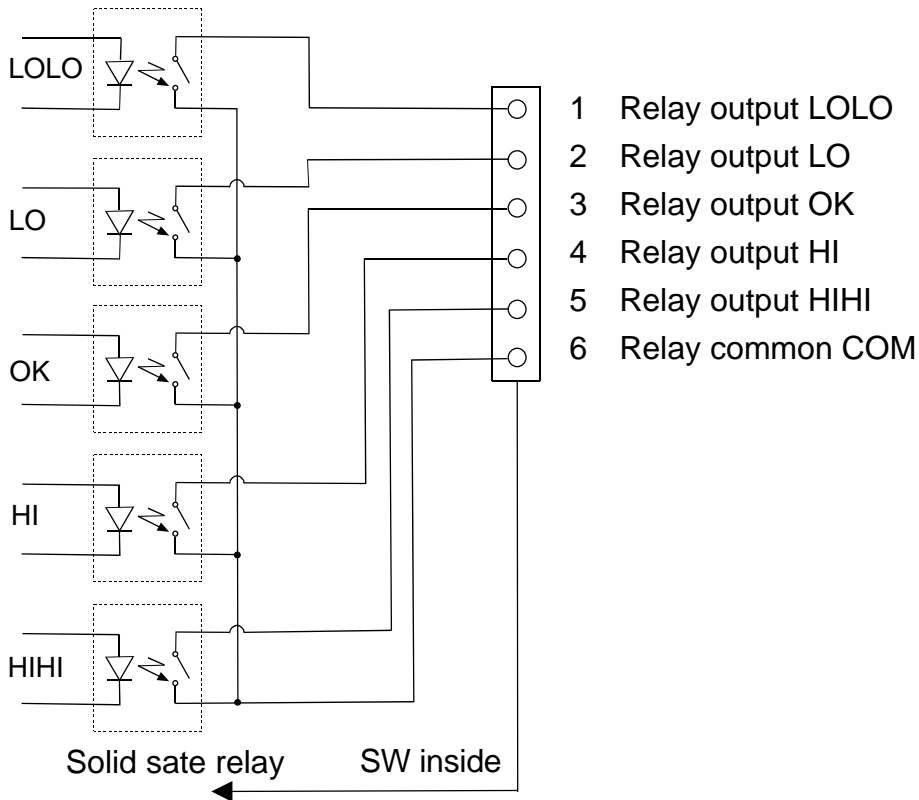

Data format

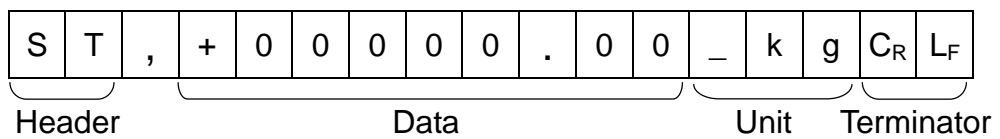

❑ There are 4 headers for the weighing data.

- ST: Stable weighing data
- QT: Stable counting data
- US: Unstable weighing data
- OL: Out of weighing range

❑ The data consists of 9 characters including the polarity and decimal point.

❑ There are 5 units.

- \_ k g: Weighing mode "kg"
- \_ \_ g: Weighing mode "g"
- \_ l b: Weighing mode "lb"
- \_ o z: Weighing mode "oz"
- \_ PC: Counting mode "pcs"

❑ As a terminator, C<sub>R</sub>L<sub>F</sub> is always output.

Data example

Weighing data "kg" (+)	S	T	,	+	0	0	1	2	.	3	4	5	_	k	g	C <sub>R</sub>	L <sub>F</sub>
Weighing data "g" (-)	S	T	,	-	0	0	0	0	1	2	3	4	_	_	g	C <sub>R</sub>	L <sub>F</sub>
Counting data "pcs" (+)	Q	T	,	+	0	0	0	1	2	3	4	5	_	P	C	C <sub>R</sub>	L <sub>F</sub>
Out of weighing range (+)	O	L	,	+	9	9	9	9	.	9	9	9	_	k	g	C <sub>R</sub>	L <sub>F</sub>

Data output mode (*Prt*)

Command mode

The scale is controlled by commands that come from an external device such as a personal computer. For details, refer to "14.2.3. Command mode".

Stream mode (*Prt 0*)

Data is sent continuously. The data update rate is approximately 10 times per second, the same as the display refresh rate.

There will be no output during the setting procedures.

Print key mode (*Prt 2*)

When the weight display is stable, data is sent by pressing the **PRINT** key. At this time, the display flashes once to indicate that the data is sent.

Auto-print mode +/- data (*Prt 3*)

When the weight display is stable at  $\pm 5d$  ( $d$  = minimum display in kg) and above  $+5d$  or below  $-5d$ , the data is sent. The next transmission can not occur until after the weight display falls between  $-4d$  and  $+4d$ .

Auto-print mode + data (*Prt 4*)

When the weight display is stable at  $+5d$  ( $d$  = minimum display in kg) and above, the data is sent. The next transmission can not occur until after the weight display falls  $+4d$  or below.

Auto-print mode +/- data and OK (*Prt 5*)

When the weight display is stable and OK as a comparison result at  $\pm 5d$  ( $d$  = minimum display in kg) and above  $+5d$  or below  $-5d$ , the data is sent. The next transmission can not occur until after the weight display falls between  $-4d$  and  $+4d$ .

Auto-print mode + data and OK (*Prt 6*)

When the weight display is stable and OK as a comparison result at  $+5d$  ( $d$  = minimum display in kg) and above, the data is sent. The next transmission can not occur until after the weight display falls  $+4d$  or below.

Baud Rate (*bPS*)

Select the baud rate according to the device to be connected.

2400 bps (*bPS 0*)      Select 2400 bps to connect to an AD-8121 printer.

4800 bps (*bPS 1*)

9600 bps (*bPS 2*)

### 14.2.3. Command mode

In the command mode, the scale is controlled by commands that come from an external device such as a personal computer.

#### Command List

Command	Description	Remarks
Q	Send data immediately.	
Z	Zero the scale when the weight is stable.	Same as the <b>ZERO</b> key.
T	Tare the scale when the weight is stable.	Same as the <b>TARE</b> key.
U	Switch the weighing unit.	Same as the <b>UNITS</b> key.
?H3	When the five-level comparator mode is used: Not used When the three-level comparator mode is used: Not used When the seven-level comparator mode is used: Send the current level 5 upper limit value.	Send a setting value.  Function settings Five-level ( $\llbracket P-L \square \rrbracket$ ) Three-level ( $\llbracket P-L 1 \rrbracket$ ) Seven-level ( $\llbracket P-L \tilde{\ } \rrbracket$ )
?H2	When the five-level comparator mode is used: Send the current HHI limit value. When the three-level comparator mode is used: Send the current HI limit value. When the seven-level comparator mode is used: Send the current level 4 upper limit value.	
?H1	When the five-level comparator mode is used: Send the current HI limit value. When the three-level comparator mode is used: Not used When the seven-level comparator mode is used: Send the current level 3 upper limit value.	
?L1	When the five-level comparator mode is used: Send the current LO limit value. When the three-level comparator mode is used: Not used When the seven-level comparator mode is used: Send the current level 3 lower limit value.	
?L2	When the five-level comparator mode is used: Send the current LOLO limit value. When the three-level comparator mode is used: Send the current LO limit value. When the seven-level comparator mode is used: Send the current level 2 lower limit value.	
?L3	When the five-level comparator mode is used: Not used When the three-level comparator mode is used: Not used When the seven-level comparator mode is used: Send the current level 1 lower limit value.	

Command	Description	Remarks
H3	When the five-level comparator mode is used: Not used When the three-level comparator mode is used: Not used When the seven-level comparator mode is used: Set the level 5 upper limit value.	Set the six-digit value excluding the polarity and decimal point
H2	When the five-level comparator mode is used: Set the HHI limit value. When the three-level comparator mode is used: Set the HI limit value. When the seven-level comparator mode is used: Set the level 4 upper limit value.	
H1	When the five-level comparator mode is used: Set the HI limit value. When the three-level comparator mode is used: Not used When the seven-level comparator mode is used: Set the level 3 upper limit value.	
L1	When the five-level comparator mode is used: Set the LO limit value. When the three-level comparator mode is used: Not used When the seven-level comparator mode is used: Set the level 3 lower limit value.	
L2	When the five-level comparator mode is used: Set the LOLO limit value. When the three-level comparator mode is used: Set the LO limit value. When the seven-level comparator mode is used: Set the level 2 lower limit value.	
L3	When the five-level comparator mode is used: Not used When the three-level comparator mode is used: Not used When the seven-level comparator mode is used: Set the level 1 lower limit value.	

Command examples (“\_” indicates “Space” (20H).)

The examples below are for the function setting “*RCU 1*” (Reply to commands).

- Request the weight data.

Command 

Q	C <sub>R</sub>	L <sub>F</sub>
---	----------------	----------------

Reply 

S	T	,	+	0	0	1	2	.	3	4	5	_	k	g	C <sub>R</sub>	L <sub>F</sub>
U	S	,	+	0	0	0	7	.	8	9	0	_	k	g	C <sub>R</sub>	L <sub>F</sub>
O	L	,	+	9	9	9	9	.	9	9	9	_	k	g	C <sub>R</sub>	L <sub>F</sub>

 Stable positive data  
 Unstable positive data  
 ‘E’ display

- Zero the scale. (No reply for the function setting “*RCU 0*”.)

Command 

Z	C <sub>R</sub>	L <sub>F</sub>
---	----------------	----------------

Reply 

Z	C <sub>R</sub>	L <sub>F</sub>
---	----------------	----------------

 The scale is in a condition that zero operation is possible.

- Tare the scale. (No reply for the function setting “*RCU 0*”.)

Command 

T	C <sub>R</sub>	L <sub>F</sub>
---	----------------	----------------

Reply 

T	C <sub>R</sub>	L <sub>F</sub>
---	----------------	----------------

 The scale is in a condition that tare operation is possible.

- Switch the weighing unit. (No reply for the function setting “*RCU 0*”.)

Command 

U	C <sub>R</sub>	L <sub>F</sub>
---	----------------	----------------

Reply 

U	C <sub>R</sub>	L <sub>F</sub>
---	----------------	----------------

 Switch the weighing unit to the next weighing unit.

- Five-level comparator mode...Not used

Three-level comparator mode...Not used

Seven-level comparator mode...Send the current level 5 upper limit value.

Command 

?	H	3	C <sub>R</sub>	L <sub>F</sub>
---	---	---	----------------	----------------

Reply 

H	3	,	+	0	0	0	5	0	0	C <sub>R</sub>	L <sub>F</sub>
---	---	---	---	---	---	---	---	---	---	----------------	----------------

- Five-level comparator mode...Send the current HIHI limit value.

Three-level comparator mode...Send the current HI limit value.

Seven-level comparator mode...Send the current level 4 upper limit value.

Command 

?	H	2	C <sub>R</sub>	L <sub>F</sub>
---	---	---	----------------	----------------

Reply 

H	2	,	+	0	0	0	4	0	0	C <sub>R</sub>	L <sub>F</sub>
---	---	---	---	---	---	---	---	---	---	----------------	----------------

- Five-level comparator mode...Send the current HI limit value.

Three-level comparator mode...Not used

Seven-level comparator mode...Send the current level 3 upper limit value.

Command 

?	H	1	C <sub>R</sub>	L <sub>F</sub>
---	---	---	----------------	----------------

Reply 

H	1	,	+	0	0	0	3	0	0	C <sub>R</sub>	L <sub>F</sub>
---	---	---	---	---	---	---	---	---	---	----------------	----------------

- ❑ Five-level comparator mode... Send the current LO limit value.  
Three-level comparator mode... Not used  
Seven-level comparator mode... Send the current level 3 lower limit value.

Command 

?	L	1	C <sub>R</sub>	L <sub>F</sub>
---	---	---	----------------	----------------

Reply 

L	1	,	+	0	0	0	2	0	0	C <sub>R</sub>	L <sub>F</sub>
---	---	---	---	---	---	---	---	---	---	----------------	----------------

- ❑ Five-level comparator mode... Send the current LOLO limit value.  
Three-level comparator mode... Send the current LO limit value.  
Seven-level comparator mode... Send the current level 2 lower limit value.

Command 

?	L	2	C <sub>R</sub>	L <sub>F</sub>
---	---	---	----------------	----------------

Reply 

L	2	,	+	0	0	0	1	0	0	C <sub>R</sub>	L <sub>F</sub>
---	---	---	---	---	---	---	---	---	---	----------------	----------------

- ❑ Five-level comparator mode... Not used  
Three-level comparator mode... Not used  
Seven-level comparator mode... Send the current level 1 lower limit value.

Command 

?	L	3	C <sub>R</sub>	L <sub>F</sub>
---	---	---	----------------	----------------

Reply 

L	3	,	+	0	0	0	0	0	0	C <sub>R</sub>	L <sub>F</sub>
---	---	---	---	---	---	---	---	---	---	----------------	----------------

- ❑ Five-level comparator mode... Not used  
Three-level comparator mode... Not used  
Seven-level comparator mode... Set the level 5 upper limit value.  
(No reply for the function setting "ALP 0".)  
Set the six-digit value excluding the polarity and decimal point.

Command 

H	3	,	+	0	0	0	5	0	0	C <sub>R</sub>	L <sub>F</sub>
---	---	---	---	---	---	---	---	---	---	----------------	----------------

Reply 

H	3	,	+	0	0	0	5	0	0	C <sub>R</sub>	L <sub>F</sub>
---	---	---	---	---	---	---	---	---	---	----------------	----------------

- ❑ Five-level comparator mode... Set the HIHI limit value.  
Three-level comparator mode... Set the HI limit value.  
Seven-level comparator mode... Set the level 4 upper limit value.  
(No reply for the function setting "ALP 0".)  
Set the six-digit value excluding the polarity and decimal point.

Command 

H	2	,	+	0	0	0	4	0	0	C <sub>R</sub>	L <sub>F</sub>
---	---	---	---	---	---	---	---	---	---	----------------	----------------

Reply 

H	2	,	+	0	0	0	4	0	0	C <sub>R</sub>	L <sub>F</sub>
---	---	---	---	---	---	---	---	---	---	----------------	----------------

- ❑ Five-level comparator mode... Set the HI limit value.  
Three-level comparator mode... Not used  
Seven-level comparator mode... Set the level 3 upper limit value.  
(No reply for the function setting "ALP 0".)  
Send the six-digit value excluding the polarity and decimal point.

Command 

H	1	,	+	0	0	0	3	0	0	C <sub>R</sub>	L <sub>F</sub>
---	---	---	---	---	---	---	---	---	---	----------------	----------------

Reply 

H	1	,	+	0	0	0	3	0	0	C <sub>R</sub>	L <sub>F</sub>
---	---	---	---	---	---	---	---	---	---	----------------	----------------

- ❑ Five-level comparator mode...Set the LO limit value.  
Three-level comparator mode...Not used  
Seven-level comparator mode...Set the level 3 lower limit value.  
(No reply for the function setting "ACE 0".)  
Send the six-digit value excluding the polarity and decimal point.

Command 

L	1	,	+	0	0	0	2	0	0	C <sub>R</sub>	L <sub>F</sub>
---	---	---	---	---	---	---	---	---	---	----------------	----------------

Reply 

L	1	,	+	0	0	0	2	0	0	C <sub>R</sub>	L <sub>F</sub>
---	---	---	---	---	---	---	---	---	---	----------------	----------------

- ❑ Five-level comparator mode...Set the LOLO limit value.  
Three-level comparator mode...Set the LO limit value.  
Seven-level comparator mode...Set the level 2 lower limit value.  
(No reply for the function setting "ACE 0".)  
Send the six-digit value excluding the polarity and decimal point.

Command 

L	2	,	+	0	0	0	1	0	0	C <sub>R</sub>	L <sub>F</sub>
---	---	---	---	---	---	---	---	---	---	----------------	----------------

Reply 

L	2	,	+	0	0	0	1	0	0	C <sub>R</sub>	L <sub>F</sub>
---	---	---	---	---	---	---	---	---	---	----------------	----------------

- ❑ Five-level comparator mode...Not used  
Three-level comparator mode...Not used  
Seven-level comparator mode...Set the level 1 lower limit value.  
(No reply for the function setting "ACE 0".)  
Send the six-digit value excluding the polarity and decimal point.

Command 

L	3	,	+	0	0	0	0	0	0	C <sub>R</sub>	L <sub>F</sub>
---	---	---	---	---	---	---	---	---	---	----------------	----------------

Reply 

L	3	,	+	0	0	0	0	0	0	C <sub>R</sub>	L <sub>F</sub>
---	---	---	---	---	---	---	---	---	---	----------------	----------------

Replies to the commands other than examples above when the function setting "ACE 1" is selected.

- ❑ The scale is not in a state where a command could be executed. Then, the scale will reply "I".  
Command 

Z	C <sub>R</sub>	L <sub>F</sub>
---	----------------	----------------

  
Reply 

I	C <sub>R</sub>	L <sub>F</sub>
---	----------------	----------------

 The scale is not in a condition that zero operation is possible.
- ❑ Command does not exist for the scale. Then, the scale will reply "?".  
Command 

B	C <sub>R</sub>	L <sub>F</sub>
---	----------------	----------------

  
Reply 

?	C <sub>R</sub>	L <sub>F</sub>
---	----------------	----------------

 The scale received an undefined command.
- ❑ When the function setting "ACE 0" is selected, undefined commands are ignored and no reply is sent.



### 14.3. SW-04 RS-422 / 485

This interface allows a personal computer to connect and control up to 16 scales.

- ❑ When SW-04 is installed, the dust-tight and water-tight performance of the scale will be degraded.
- ❑ SW-04 unit includes an interface board, a connector cable (10 pins), two cable glands (for cable diameter 3.5 to 7.0 mm) and two screws (M3x8).

#### 14.3.1. Installing SW-04

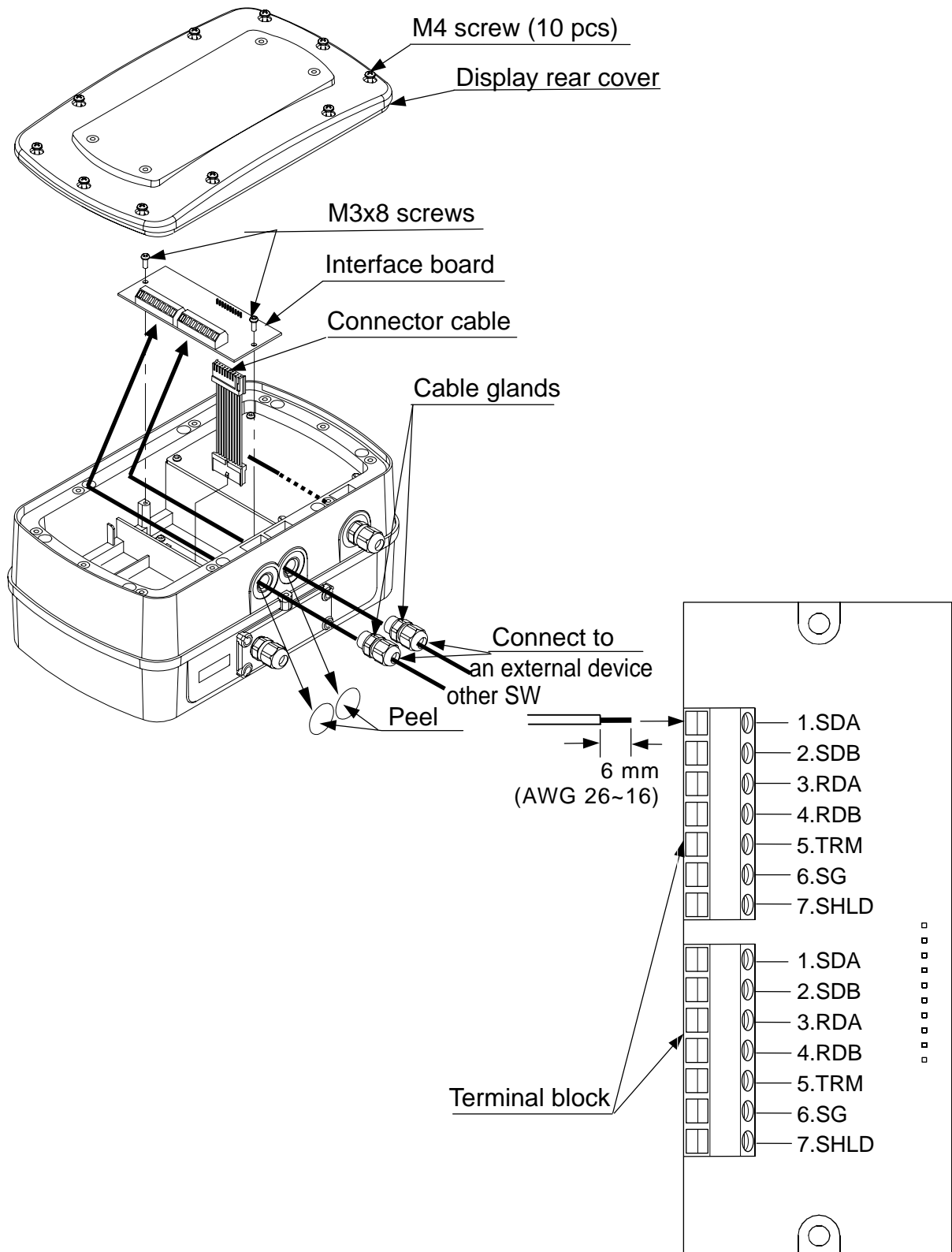

- ❑ The installation procedure is the same as for SW-03. Refer to “14.2.1. Installing SW-03”.
- ❑ Set the function settings “*bPS*”, “*btPr*”, “*PrL*”, “*S iF*”, “*Adr*” and “*ALP*” as necessary.
- ❑ Before using SW-04, the function setting “*S iF*” must be set to specify whether RS-422 or RS-485 is used.  
To connect more than one scale to a computer, set a different address to each scale using the function setting “*Adr*”.

### 14.3.2. SW-04 specifications

#### RS-422/485 interface

Transmission system	EIA RS-422 / 485
Transmission form	Asynchronous, bi-directional, half-duplex
Data format	Baud rate: 2400, 4800, 9600 bps
	Data bits: 7 bits + parity 1bit (EVEN / ODD) or 8 bits (non parity)
Start bit:	1 bit
Stop bit:	1 bit
Code:	ASCII
Terminator:	C <sub>R</sub> L <sub>F</sub> (C <sub>R</sub> :0Dh, L <sub>F</sub> :0Ah)

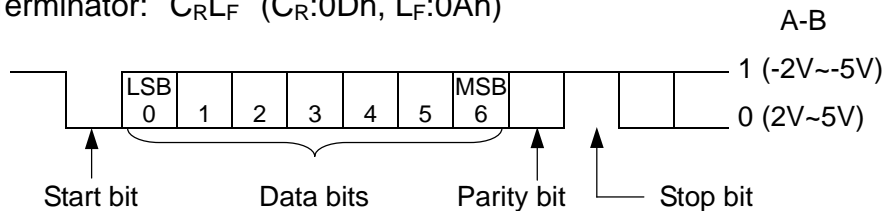

#### Circuit diagram

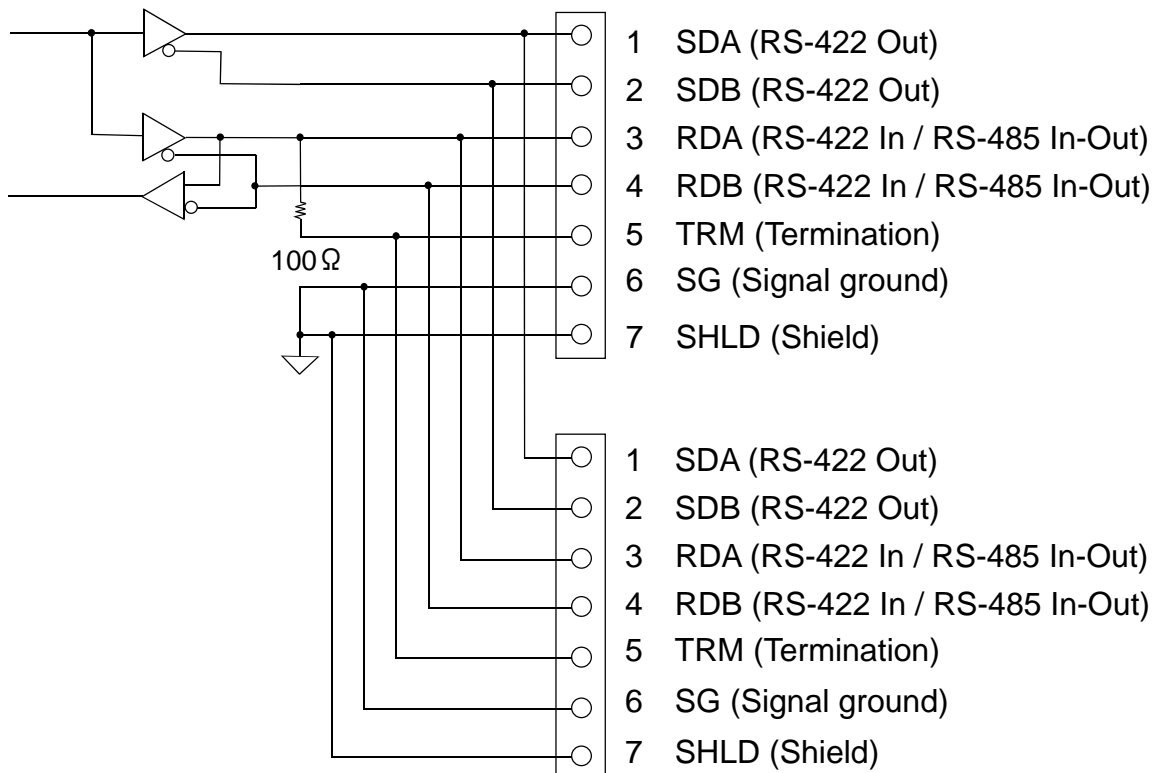

## Example of connection

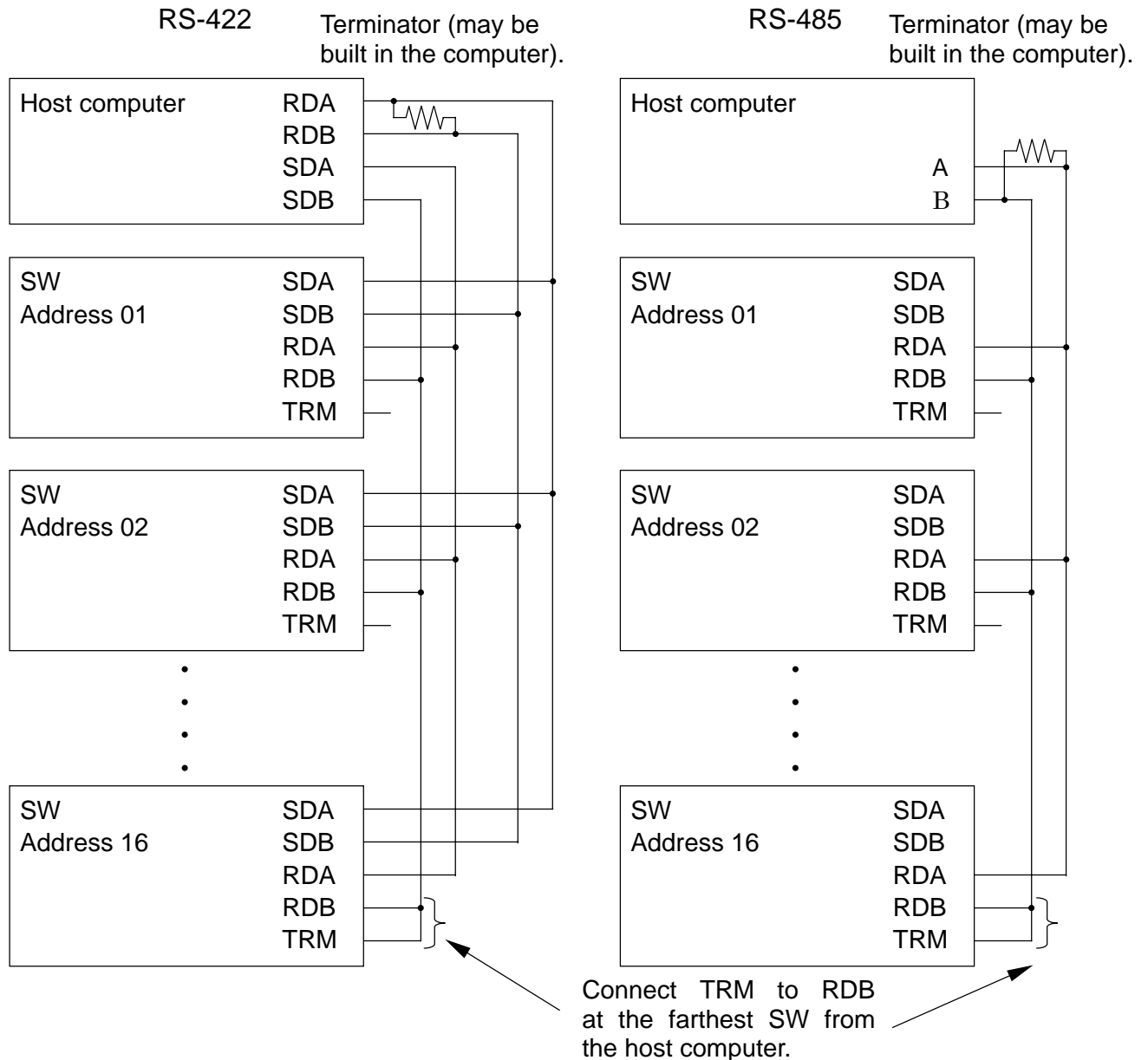

- ❑ The polarity (A, B) of the host computer signal depends on the computer model. Check the technical manual of the computer.

## Data format

The data format for the RS-422/485 is the same as the RS-232C except the following:

- ❑ When used with the function setting “*S iF 1*” (RS-422) or “*S iF 2*” (RS-485), set a different address to each scale using the function setting “*Adr ##*”. (##=01 to 99)
- ❑ Start all commands with “*@##*” (## is the address of the scale to send a command). All replies from the scale start with “*@##*”. The format after “*@##*” is the same as the RS-232C, both in commands and replies.
- ❑ When used with the RS-485 interface (function setting: “*S iF 2*”), note the following:
  - When sending commands continuously, leave an interval of 500 ms or more between commands.
  - Do not use stream mode (function setting: “*Prt 0*”) when sending commands. Commands will not be received correctly and will be invalid.

Command examples (“\_” indicates “Space” (20H).)

The examples below are for the function setting “*ACL* 1” (Reply to commands).

The address ## = 23.

- Request a weight data.

Command 

@	2	3	Q	C <sub>R</sub>	L <sub>F</sub>
---	---	---	---	----------------	----------------

Reply 

@	2	3	S	T	,	+	0	0	1	2	.	3	4	5	_	k	g	C <sub>R</sub>	L <sub>F</sub>	Stable data
@	2	3	U	S	,	+	0	0	0	7	.	8	9	0	_	k	g	C <sub>R</sub>	L <sub>F</sub>	Unstable data
@	2	3	O	L	,	+	9	9	9	9	.	9	9	9	_	k	g	C <sub>R</sub>	L <sub>F</sub>	“E” display

- Zero the scale. (No reply for the function setting “*ACL* 0 “.)

Command 

@	2	3	Z	C <sub>R</sub>	L <sub>F</sub>
---	---	---	---	----------------	----------------

Reply 

@	2	3	Z	C <sub>R</sub>	L <sub>F</sub>
---	---	---	---	----------------	----------------

 The scale is in a condition that zero operation is possible.

- Send the current LO limit value.

Command 

@	2	3	?	L	1	C <sub>R</sub>	L <sub>F</sub>
---	---	---	---	---	---	----------------	----------------

Reply 

@	2	3	L	1	,	+	0	0	0	2	0	0	C <sub>R</sub>	L <sub>F</sub>
---	---	---	---	---	---	---	---	---	---	---	---	---	----------------	----------------

---

# 15. MAINTENANCE

---

## 15.1. Notes on maintenance

- Do not disassemble the scale. Contact your local A&D dealer if the scale needs service or repair.
- Use the original packaging for transportation.
- Do not use organic solvents to clean the scale. Use a warm lint free cloth dampened with a mild detergent.
- Calibrate the scale periodically to maintain the weighing accuracy.

## 15.2. Error codes

### Overload error



Indicates that an object beyond the weighing capacity has been placed on the weighing pan.  
Remove the object from the weighing pan.

### Underload error

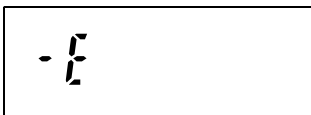

Indicates that the weight sensor receives a strong upward force. Check if the weighing pan is touching anything or if there is anything in the base. There is a possibility that the weight sensor or internal circuit may have a problem.

### Unit weight error

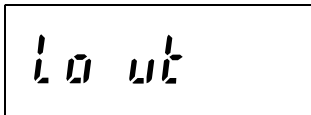

Indicates that the sample weight is too light to set the unit weight in the counting mode.

### CAL error

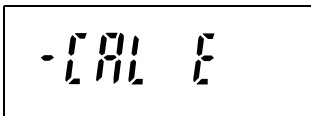

Indicates that the calibration procedure is canceled because the calibration weight is too light.  
Check that the weighing pan is installed properly and the mass of the calibration weight.

### Low battery



Indicates that the HC-02i battery is depleted.  
Charge the battery immediately.

### Other

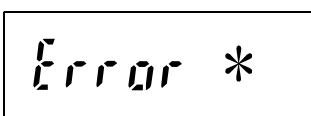

There may be an internal malfunction.  
(\* indicates an error number.)

**Note: If the error persists or other errors occur, contact your local A&D dealer.**

# 16. SPECIFICATIONS

## 16.1. Specifications

MODEL		SW-6KS	SW-15KS	SW-15KM	SW-30KM
kg	Weighing capacity	6	15	15	30
	Minimum display	0.002	0.005	0.005	0.01
		0.001 *	0.002 *	0.002 *	0.005 *
		0.0005	0.001	0.001	0.002
g	Weighing capacity	6000	15000	15000	30000
	Minimum display	2	5	5	10
		1 *	2 *	2 *	5 *
		0.5	1	1	2
lb	Weighing capacity	13	33	33	66
	Minimum display	0.005	0.01	0.01	0.02
		0.002*	0.005*	0.005*	0.01*
		0.001	0.002	0.002	0.005
oz	Weighing capacity	210	520	520	1050
	Minimum display	0.1	0.2	0.2	0.5
		0.05*	0.1*	0.1*	0.2*
		0.02	0.05	0.05	0.1
lb-oz	Weighing capacity	13	33	33	66
	Minimum display	0.1	0.1	0.1	0.1
Number of samples	5 (can be changed to 10, 20, 50 or 100) pieces				
Maximum count	120,000 pcs	150,000 pcs	150,000 pcs	150,000 pcs	150,000 pcs
Minimum unit weight	0.00005 kg	0.0001 kg	0.0001 kg	0.0001 kg	0.0002 kg
Repeatability (Std. deviation)	0.001 kg	0.002 kg	0.002 kg	0.002 kg	0.005 kg
Linearity	±0.002 kg	±0.005 kg	±0.005 kg	±0.005 kg	±0.01 kg
Sensitivity drift	±20 ppm / °C (5°C to 35°C / 41°F to 95°F)				
Display	Weight display: 7 segment LED display (character height 14.6 mm) Comparison results: red / yellow / green / yellow / red LED				
Display update	10 times per second				
Operating conditions	-10°C to 40°C / 14°F to 104°F				
Power supply	AC main (100 V to 240 V, 50/60 Hz, 20 VA) or optional SLA battery (continuous operation of 90 hours depending on how the scale is used)				
Weighing pan size	250 x 250 mm / 9.8 x 9.8 in.		300 x 380 mm / 11.8 x 15.0 in.		
Dimensions (Models with a display pole)	250 (W) x 480 (D) x 353.5 (H) mm 9.8 (W) x 18.9 (D) x 13.9 (H) in.		300 (W) x 601 (D) x 722.5 (H) mm 11.8 (W) x 23.7 (D) x 28.4 (H) in.		
Mass (approximately) (Models with a display pole)	7.7 kg / 17.0 lb		13.0 kg / 28.7 lb		
Calibration weight (factory setting)	6 kg 12 lb	15 kg 30 lb	15 kg 30 lb	30 kg 60 lb	

\* Factory setting

MODEL		SW-60KM	SW-150KM	SW-60KL	SW-150KL
kg	Weighing capacity	60	150	60	150
	Minimum display	0.02	0.05	0.02	0.05
		0.01 *	0.02 *	0.01 *	0.02 *
		0.005	0.01	0.005	0.01
lb	Weighing capacity	130	330	130	330
	Minimum display	0.05	0.1	0.05	0.1
		0.02*	0.05*	0.02*	0.05*
		0.01	0.02	0.01	0.02
oz	Weighing capacity	2100	5200	2100	5200
	Minimum display	1	2	1	2
		0.5*	1*	0.5*	1*
		0.2	0.5	0.2	0.5
lb-oz	Weighing capacity	130	330	130	330
	Minimum display	1	1	1	1
Number of samples		5 (can be changed to 10, 20, 50 or 100) pieces			
Maximum count		120,000 pcs	150,000 pcs	120,000 pcs	150,000 pcs
Minimum unit weight		0.0005 kg	0.001 kg	0.0005 kg	0.001 kg
Repeatability (Std. deviation)		0.01 kg	0.02 kg	0.01 kg	0.02 kg
Linearity		±0.02 kg	±0.05 kg	±0.02 kg	±0.05 kg
Sensitivity drift		±20 ppm / °C (5°C to 35°C / 41°F to 95°F)			
Display		Weight display: 7 segment LED display (character height 14.6 mm) Comparison results: red / yellow / green / yellow / red LED			
Display update		10 times per second			
Operating conditions		-10°C to 40°C / 14°F to 104°F			
Power supply		AC main (100 V to 240 V, 50/60 Hz, 20 VA) or optional SLA battery (continuous operation of 90 hours depending on how the scale is used)			
Weighing pan size		300 x 380 mm / 11.8 x 15.0 in.		390 x 530 mm / 15.4 x 20.9 in.	
Dimensions (Models with a display pole)		300 (W) x 601 (D) x 722.5 (H) mm 11.8 (W) x 23.7 (D) x 28.4 (H) in.		390 (W) x 751 (D) x 722.5 (H) mm 15.4 (W) x 29.6 (D) x 28.4 (H) in.	
Mass (approximately) (Models with a display pole)		13.0 kg / 28.7 lb		16.2 kg / 35.7 lb	
Calibration weight (factory setting)		60 kg 120 lb	150 kg 300 lb	60 kg 120 lb	150 kg 300 lb

\* Factory setting

#### Options

HC-02i SAL Sealed Lead Acid battery (YUASA NP4-6 recommended)

SW-03 RS-232C / Relay output

SW-04 RS-422 / 485

**Note: The options, SW-03 and SW-04, can not be used at the same time.**

## 16.2. External dimensions

- SW-6KS / SW-15KS (with a display pole)

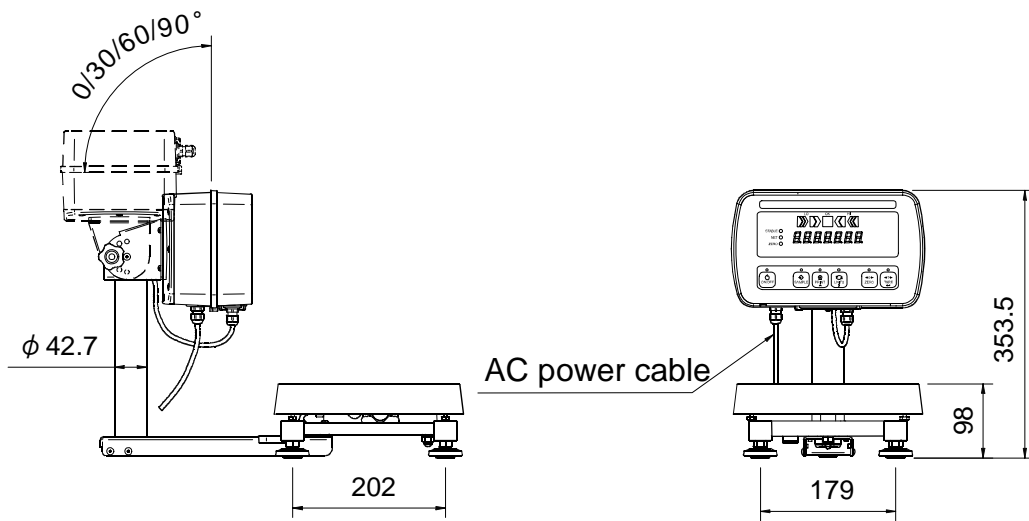

- SW-15KM / SW-30KM / SW-60KM / SW-150KM (with a display pole)

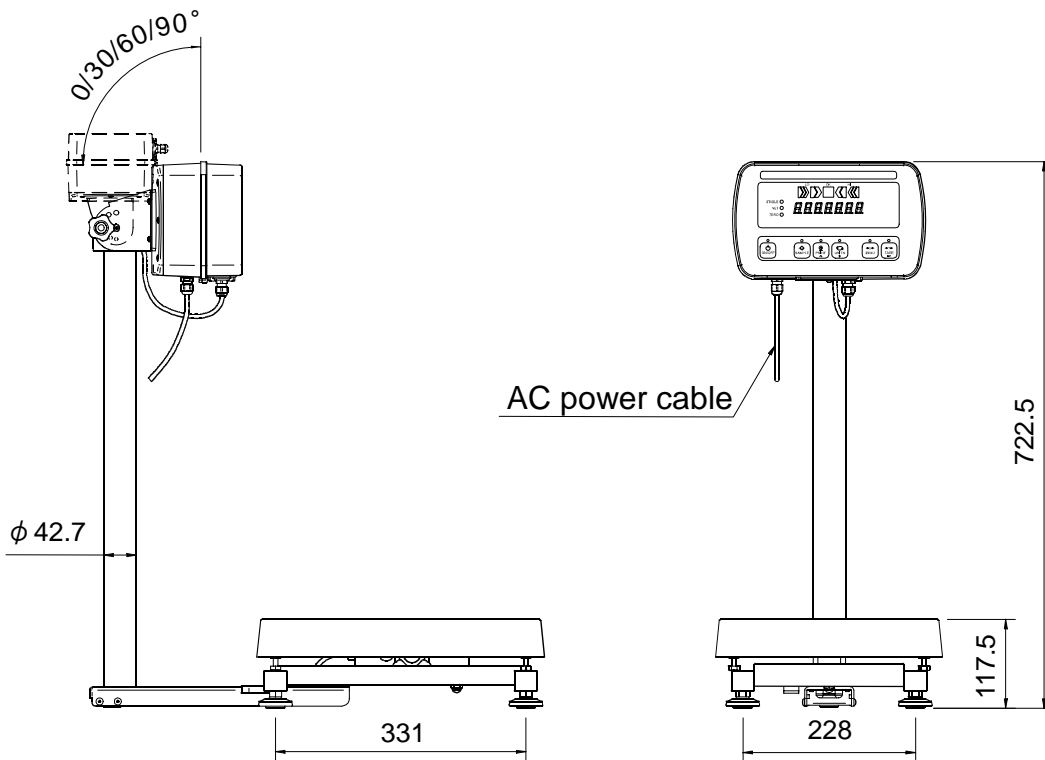

Unit: mm



●SW-60KL / SW-150KL (with a display pole)

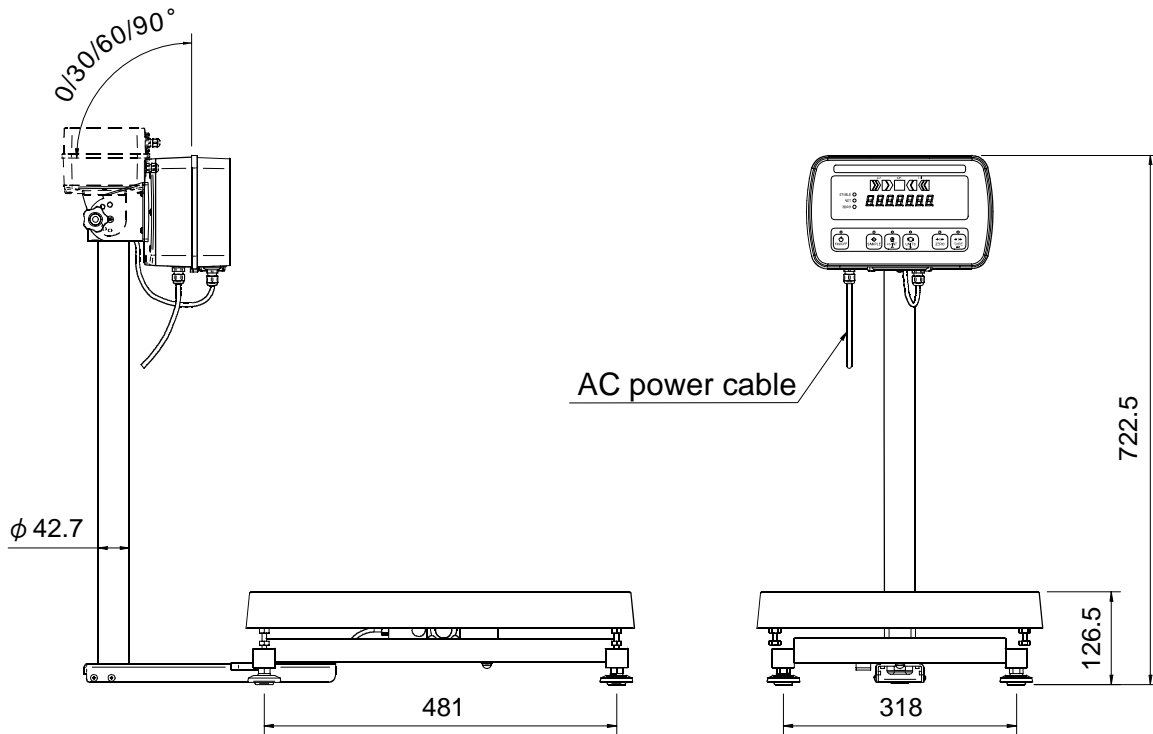

●Display with a stand attached

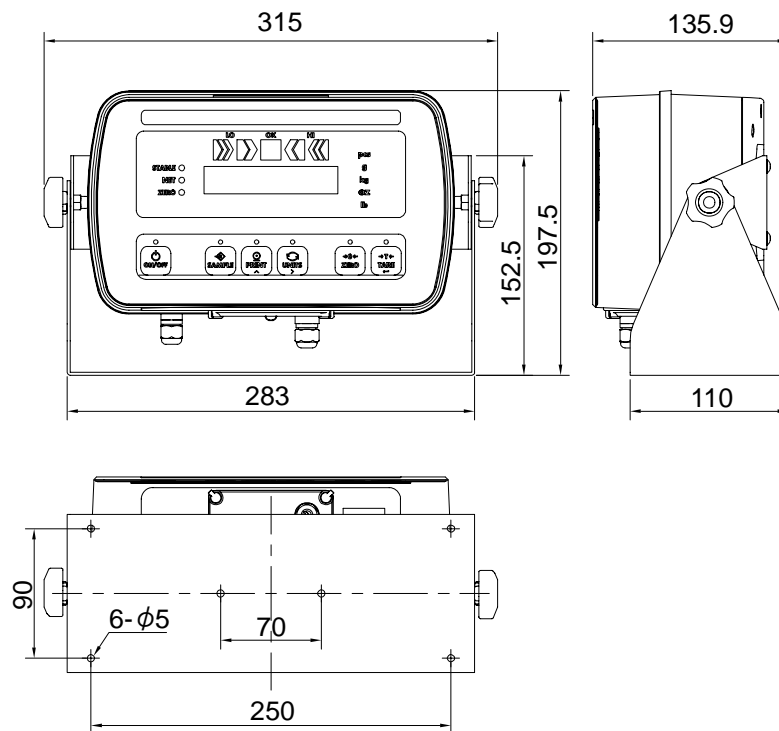

Unit: mm

# GRAVITY ACCELERATION MAP

## Values of gravity at various locations

Amsterdam	9.813 m/s <sup>2</sup>	Manila	9.784 m/s <sup>2</sup>
Athens	9.807 m/s <sup>2</sup>	Melbourne	9.800 m/s <sup>2</sup>
Auckland NZ	9.799 m/s <sup>2</sup>	Mexico City	9.779 m/s <sup>2</sup>
Bangkok	9.783 m/s <sup>2</sup>	Milan	9.806 m/s <sup>2</sup>
Birmingham	9.813 m/s <sup>2</sup>	New York	9.802 m/s <sup>2</sup>
Brussels	9.811 m/s <sup>2</sup>	Oslo	9.819 m/s <sup>2</sup>
Buenos Aires	9.797 m/s <sup>2</sup>	Ottawa	9.806 m/s <sup>2</sup>
Calcutta	9.788 m/s <sup>2</sup>	Paris	9.809 m/s <sup>2</sup>
Cape Town	9.796 m/s <sup>2</sup>	Rio de Janeiro	9.788 m/s <sup>2</sup>
Chicago	9.803 m/s <sup>2</sup>	Rome	9.803 m/s <sup>2</sup>
Copenhagen	9.815 m/s <sup>2</sup>	San Francisco	9.800 m/s <sup>2</sup>
Cyprus	9.797 m/s <sup>2</sup>	Singapore	9.781 m/s <sup>2</sup>
Djakarta	9.781 m/s <sup>2</sup>	Stockholm	9.818 m/s <sup>2</sup>
Frankfurt	9.810 m/s <sup>2</sup>	Sydney	9.797 m/s <sup>2</sup>
Glasgow	9.816 m/s <sup>2</sup>	Taichung	9.789 m/s <sup>2</sup>
Havana	9.788 m/s <sup>2</sup>	Tainan	9.788 m/s <sup>2</sup>
Helsinki	9.819 m/s <sup>2</sup>	Taipei	9.790 m/s <sup>2</sup>
Kuwait	9.793 m/s <sup>2</sup>	Tokyo	9.798 m/s <sup>2</sup>
Lisbon	9.801 m/s <sup>2</sup>	Vancouver, BC	9.809 m/s <sup>2</sup>
London (Greenwich)	9.812 m/s <sup>2</sup>	Washington DC	9.801 m/s <sup>2</sup>
Los Angeles	9.796 m/s <sup>2</sup>	Wellington NZ	9.803 m/s <sup>2</sup>
Madrid	9.800 m/s <sup>2</sup>	Zurich	9.807 m/s <sup>2</sup>

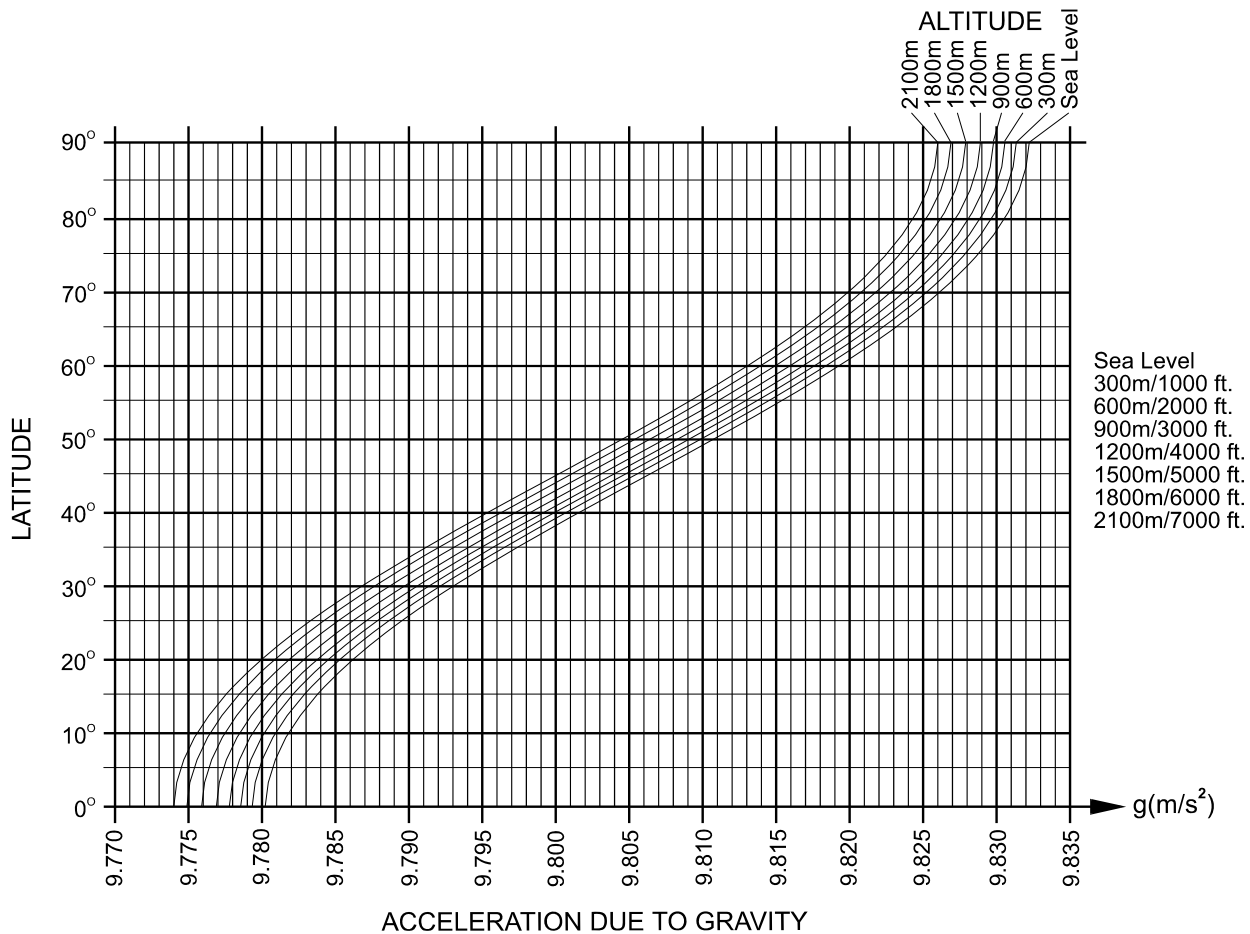

# World map

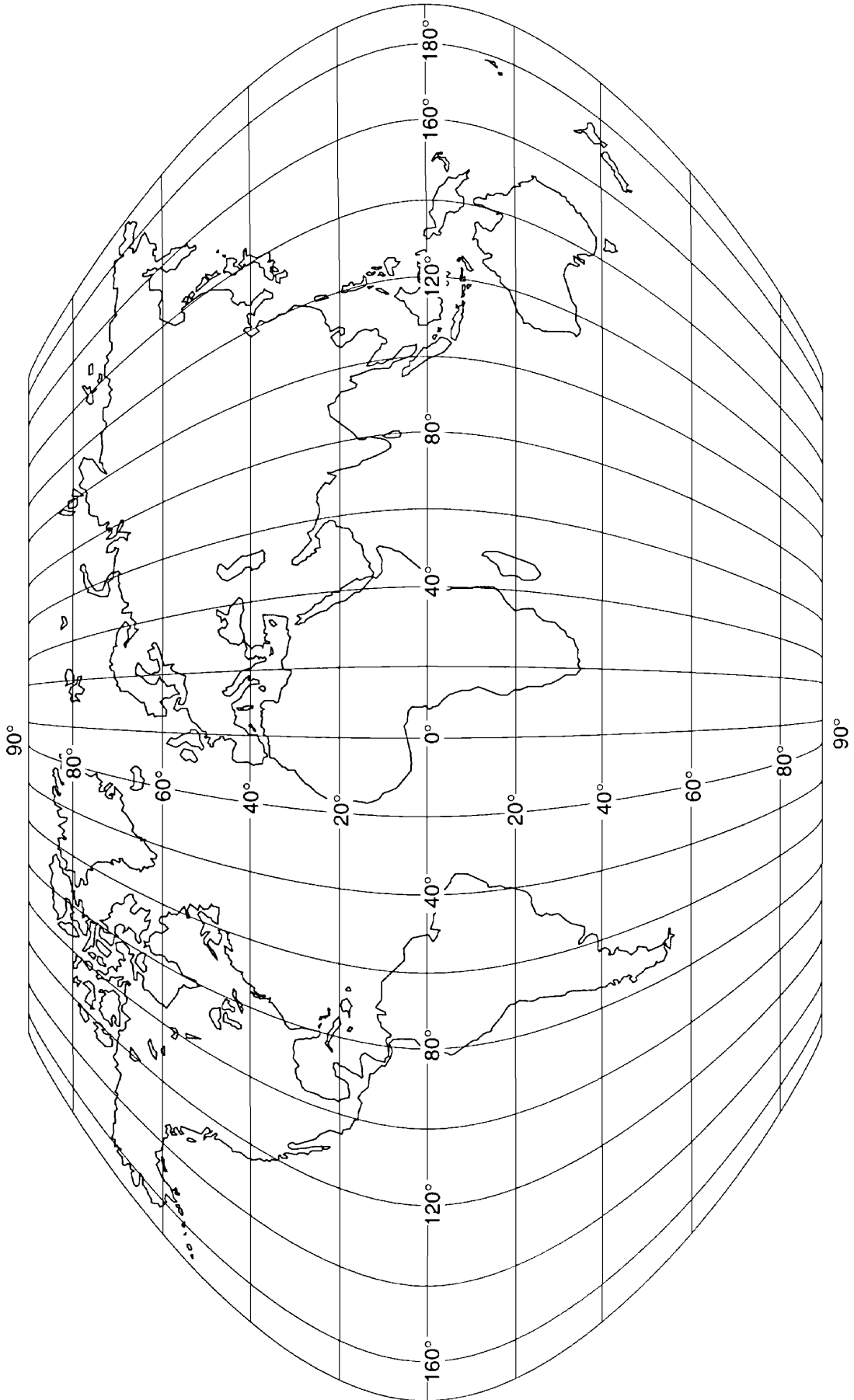











### **A&D Company, Limited**

3-23-14 Higashi-Ikebukuro, Toshima-ku, Tokyo 170-0013 JAPAN  
Telephone: [81] (3) 5391-6132 Fax: [81] (3) 5391-6148

### **A&D ENGINEERING, INC.**

1756 Automation Parkway, San Jose, California 95131 U.S.A.  
Telephone: [1] (408) 263-5333 Fax: [1] (408)263-0119

### **A&D INSTRUMENTS LIMITED <UK Office>**

Unit 24/26 Blacklands Way, Abingdon Business Park, Abingdon, Oxfordshire OX14 1DY United Kingdom  
Telephone: [44] (1235) 550420 Fax: [44] (1235) 550485

### **A&D INSTRUMENTS LIMITED <German Sales Office>**

Große Straße 13 b 22926 Ahrensburg Deutschland  
Telefon: [49] (0) 4102 459230 Telefax: [49] (0) 4102 459231

### **A&D Australasia Pty Ltd.**

32 Dew Street, Thebarton, South Australia 5031 AUSTRALIA  
Telephone: [61] (8) 8301-8100 Fax: [61] (8) 8352-7409

### **A&D KOREA Limited 한국에이.엔.디(주)**

대한민국 서울시 영등포구 여의도동 36-2 맨하탄 빌딩 8층  
( 8th Floor, Manhattan Bldg. 36-2 Yoido-dong, Youngdeungpo-ku, Seoul, KOREA )  
전화: [82] (2) 780-4101 팩스: [82] (2) 782-4280

### **A&D RUS CO., LTD.**

Компания Эй энд Ди Рус  
121357, Российская Федерация, г.Москва, ул. Вереysкая, дом 17  
( Bldg. 17, Vereyskaya st., Moscow, 121357 RUSSIAN FEDERATION )  
тел.: [7] (495) 937-33-44 факс: [7] (495) 937-55-66

### **A&D Instruments India Private Limited ऐ&डी इन्स्ट्रुमेन्ट्स इण्डिया प्रा० लिमिटेड**

509, उद्योग विहार , फेस -5, गुडगांव - 122016, हरियाणा , भारत  
( 509, Udyog Vihar, Phase-V, Gurgaon - 122 016, Haryana, India )  
फोन : 91-124-4715555 फैक्स : 91-124-4715599