

IKA

designed for scientists

EUROSTAR 200 digital



Operating instructions

EN

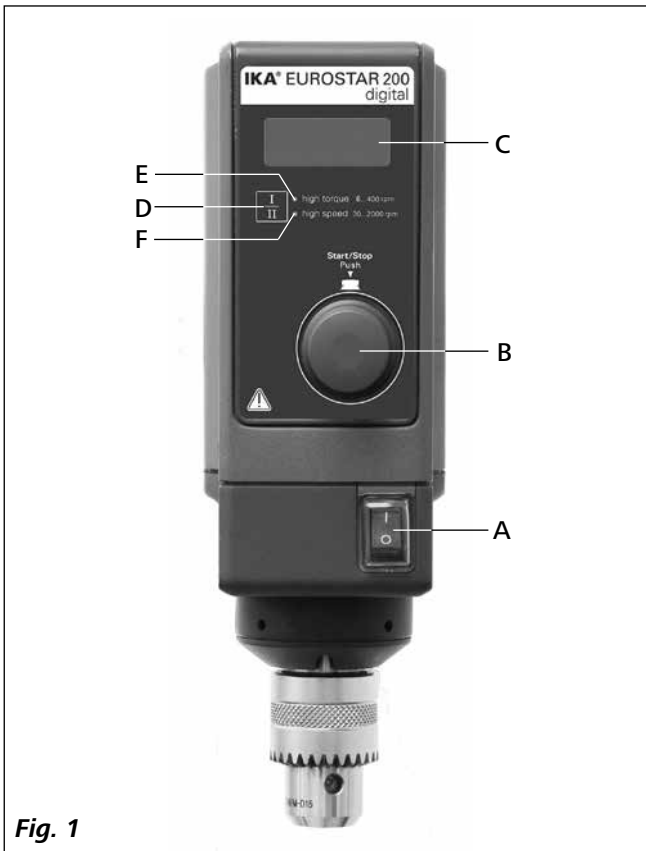

Fig. 1

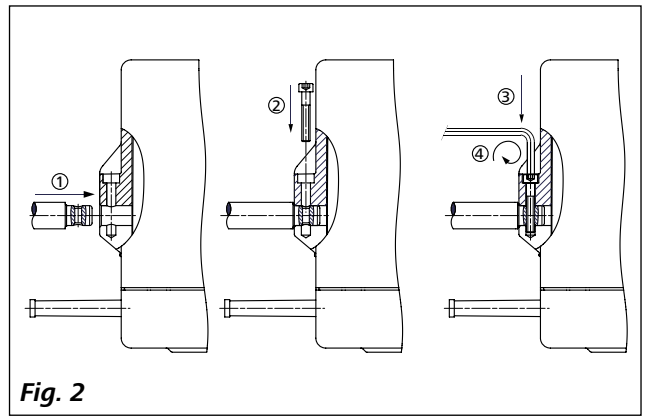

Fig. 2

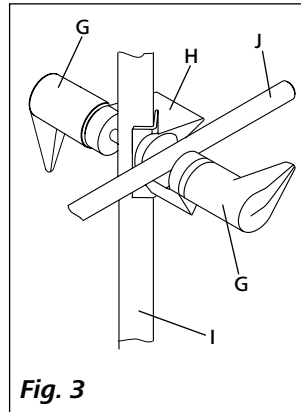

Fig. 3

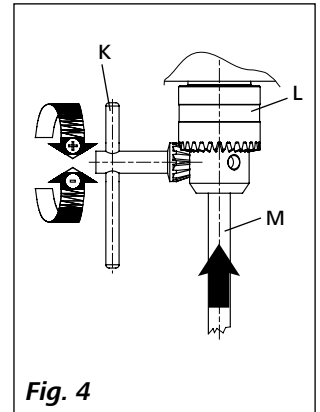

Fig. 4

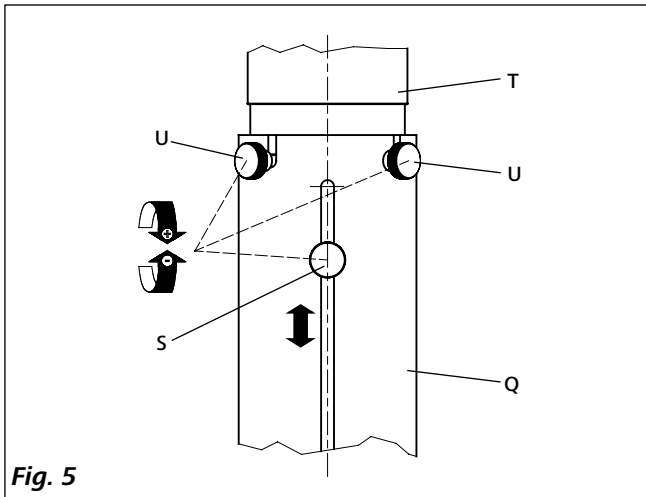

Fig. 5

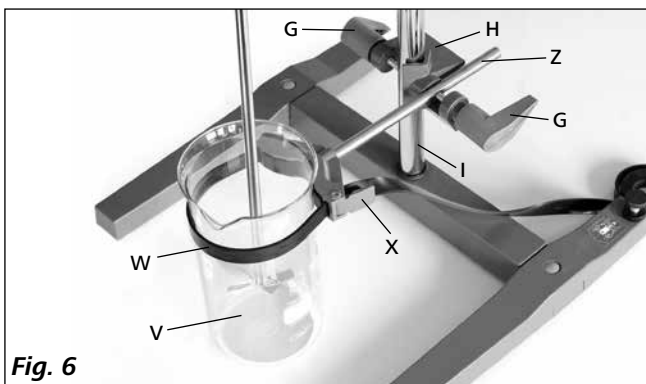

Fig. 6

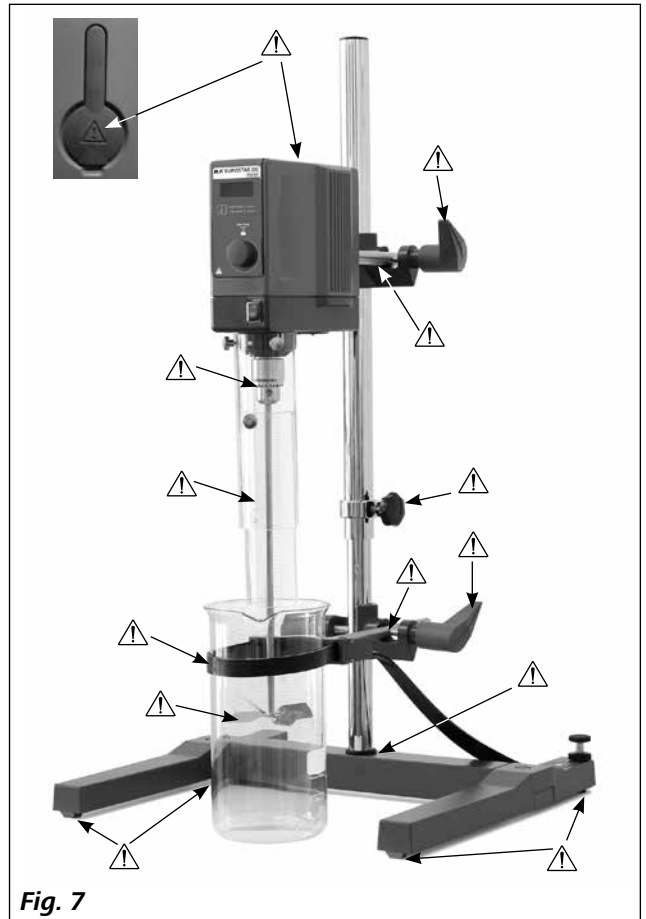

Fig. 7

Contents

	Page
Declaration of conformity	3
Explication of warning symbols	3
Safety instructions	4
Correct use	6
Unpacking	6
Drive	6
Motor protection	6
Speed – normal operation	6
Speed – overload operation	7
Output shaft	7
Speed display	7
Commissioning	7
Securing	8
Switching on the instrument	8
Maintenance and cleaning	9
Error codes	9
Warranty	10
Accessories	10
Permitted IKA ® stirrer tools	10
Technical data	11

Declaration of conformity

We declare under our sole responsibility that this product corresponds to the regulations 2014/35/EU, 2006/42/EC, 2014/30/EU and 2011/65/EU and conforms with the standards or standardized documents: EN 61010-1, EN 61010-1-2-051, EN 61326-1, EN 60529 and EN ISO 12100.

A copy of the complete EU Declaration of Conformity or further declarations of conformity can be requested at sales@ika.com.

Explication of warning symbols



General hazard



This symbol identifies information **that is of vital importance for safeguarding your health and safety**. Disregarding this information can lead to health impairment and injuries.



This symbol identifies information **that is of importance for the technically correct functioning of the system**. Disregarding this information can result in damage to the instrument or to system components.



This symbol indicates information **which is important for ensuring that the operations of the instrument are performed efficiently and for using the instrument**. Failure to observe this information can result in inaccurate results.

Safety instructions



- **Read the operating instructions in full before starting up and follow the safety instructions.**
- Keep the operating instructions in a place where it can be accessed by everyone.
- Ensure that only trained staff work with the instrument.
- Follow the safety instructions, guidelines, occupational health and safety and accident prevention regulations.
- Because the options for combining products, tools, stirring vessel, experiment and medium are nearly endless, user safety cannot be ensured simply with design requirements on the part of the product. For this reason, it may become necessary for users to take other precautionary safety measures. For example, glass device or other stirring vessels that are sensitive to mechanical stress can be damaged or shattered by an imbalance, increasing the speed too quickly or too little distance between the stirring element and the stirring vessel. Users can suffer serious injury from glass breakage or from the freely rotating stirring element.
- Uncontrolled reactions can be triggered by mixing the heated material insufficiently or by the energy generated by selecting a speed that is too high. In case of these and other increased operational hazards, users must take additional appropriate safety precautions (e.g. shatter protection).

In any case, when using critical or hazardous materials in your processes, **IKA®** recommends to use additional appropriate measures to ensure safety in the experiment. For example, users can implement measures that inhibit fire or explosions or comprehensive monitoring equipment.

Furthermore, users must make sure that the **OFF** switch of the **IKA®** product can be accessed immediately, directly and without risk at any time.



If installation or positioning cannot ensure this access at all times, an additional **EMERGENCY STOP** switch that can be easily accessed must be installed in the work area.

- Only process media that will not react dangerously to the extra energy produced through processing. This also applies to any extra energy produced in other ways, e.g. through light irradiation.
- Do not operate the instrument in explosive atmospheres, with hazardous substances or under water.

- Process pathogenic materials only in closed vessels under a suitable fume hood. Please contact **IKA®** application support if you have any question.
- The instrument is not suitable for manual operation.
- The high torque developed by the **EUROSTAR** requires particular care in the choice of stand, cross sleeve and anti-rotation element for the agitating vessel.
- Set up the stand in a spacious area on an even, stable, clean, non-slip, dry and fireproof surface.
- You must ensure that the stirring element is securely clamped in the chuck!
- Use stirring shaft protective equipment!
- The agitated vessels used for stirring have to be secured. Consider on a good stability of the entire structure.



Please pay attention to the dangerous parts of the equipment in **Fig. 7**.

- Protect the instrument and accessories from bumping and impacting.
- Check the instrument and accessories beforehand for damage each time when you use them. Do not use damaged components.
- Safe operation is only guaranteed with the accessories described in the "**Accessories**" section.
- Always switch the main switch in the **OFF** position or disconnect the power before changing stirring element and fitting allowed accessories.
- The instrument can only be disconnected from the mains supply by pulling out the mains plug or the connector plug.
- The socket for the mains cord must be easily accessible.
- Socket must be earthed (protective ground contact).
- The voltage stated on the type plate must correspond to the mains voltage.
- Please observe the permitted speed for the stirring element. Never set higher speed.
- Make certain that the unit is set at the lowest speed before commissioning; otherwise, the unit will begin running at the speed set in last operation. Gradually increase the speed.
- Pay attention when setting the speed to any imbalance of the stirrer tools and possible spraying of the medium to be stirred.



Never operate the instrument with the stirrer tools rotating freely. Ensure that parts of the body, hair, jewelry or items of clothing cannot be trapped by the rotating parts.



 **DANGER**

The operation of a free rotating shaft end is dangerous. Therefore, for safety reason, only insert through the stirring tool over the upper edge of housing at standstill.

 **DANGER**

Wear your personal protective equipment in accordance with the hazard category of the medium to be processed, otherwise there is a risk of:

- splashing of liquids
- projectile parts
- body parts, hair, clothing and jewelry getting caught.

 **DANGER**

Beware of the risk of:

- flammable materials
- glass breakage as a result of mechanical shaking power.

 **DANGER**

Reduce the speed if:

- the medium splashes out of the vessel because the speed is too high
- the instrument is not running smoothly
- the instrument begins to move around because of dynamic forces
- an error occurs.

 **DANGER**

Do not touch rotating parts during operation!

- There may be electrostatic activity between the medium and the output shaft which could cause a direct danger.
- After an interruption in the power supply or a mechanical interruption during a stirring process, the unit does not restart automatically.

- It is important to note that the surfaces of the motor (cooling fins) and certain parts of the bearing may get very hot during operation.
- Never cover the ventilation slots or cooling fins on the motor or on the instrument.
- Avoid knocking and impacting on the lower end of the shaft and the chuck gear teeth. Even minor, invisible damage can lead to imbalance and uneven shaft action.
- Ensure that the stand does not start to move.
- Imbalance of the output shaft, the chuck and in particular the stirring tools can lead to uncontrolled resonant vibrational behavior of the instrument and the whole assembly. Glass apparatus and stirrer containers can be damaged or shattered by this. It can cause injury to the operator, also can damage the rotating stirring tool. In this case exchange the stirring tool for one without imbalance or remedy the cause of the imbalance.

If there is still imbalance, return it to the dealer or the manufacturer along with a description of the fault.

- If the instrument is operated too long in overload or if the ambient temperature is too high, the instrument switches off permanently.
- The machine must only be opened by trained specialists, even during repair. The instrument must be unplugged from the power supply before opening. Live parts inside the instrument may still be live for some time after unplugging from the power supply.

 **WARNING**

Covering or parts that are capable of being removed from the unit without accessory equipment have to be reattached to the unit for safe operation in order to prevent, for example, the ingress of fluids, foreign matter, etc..

Correct use

- **Use**

For mixing/stirring liquids with low to high viscosities by various stirring tools.

Intended use: Stand device (chuck points down)

- **Range of use (indoor use only)**

- Laboratories
- Pharmacies
- Schools
- Universities

This instrument is suitable for use in all areas except:

- Residential areas
- Areas that are connected directly to a low-voltage supply network that also supplies residential areas.

The safety of the user cannot be guaranteed:

- If the instrument is operated with accessories that are not supplied or recommended by the manufacturer
- If the instrument is operated improperly or contrary to the manufacturer's specifications
- if the instrument or the printed circuit board are modified by third parties.

Unpacking

- **Unpacking**

- Please unpack the device carefully
- In the case of any damage a detailed report must be sent immediately (post, rail or forwarder).

- **Delivery scope**

- a **EUROSTAR 200 digital** overhead stirrer
- an operating instructions
- an extension arm
- a hexagonal socket screw
- a hexagon socket offset screw key
- a chuck key
- a warranty card.

Drive

The speed can be adjusted continuously over two speed range (speed range **I**, speed range **II**) with the knob (B, see **Fig. 1**).

Motor protection

The stirring instrument is suitable for continuous operation. The motor current is limited electronically. The instrument has an anti-stall and anti-overload system.

If a fault occurs, a safety circuit immediately switches off the motor permanently through a relay in the power board. A fault occurs if the safe functioning of the instrument is compromised.

Speed – normal operation

Speed - regulated (no variation in speed)

The speed is monitored and regulated by processor controlled. The target speed is constantly compared with the actual rotation speed value of the output shaft and variations corrected. This guarantees a constant speed even if the viscosity of the substance being stirred changes.

Fluctuations in mains voltage within the permitted tolerance range have no effect on the quality of regulation and constancy of speed.

The speed is set using the front knob (B, see **Fig. 1**). During normal operations the speed value on the display (C, see **Fig. 1**) corresponds to the speed of the output shaft in revolutions per minute (rpm).

Speed – overload operation

The stirrer can deliver double output for a short time to even out load peaks which could occur, for instance, if solid or semi-pourable agents are added. If the operation is in the overload range (e.g. process-related increase in viscosity), the actual speed is reduced until the stirrer torque corresponds to the nominal torque of the machine, and the target speed blinks. The possible speed is continually adapted to operating conditions, guaranteeing that speed is as close as possible to the target speed set. To protect the machine from overloading, the speed is reduced if the machine has been operated in overload mode. The target speed set then does not correspond to the actual speed of the output shaft. This condition is indicated by blinking of the target speed (overload operation).

Overload status 1:

The machine is already running in the overload range, the target speed does not yet correspond to the actual speed. This condition is maintained as long as neither the motor current nor the temperature exceeds the permitted limit values.

Display symbol: **blinking of the target speed.**

When the load goes back to the normal range, the target speed stops blinking and corresponds to the actual speed.

Overload status 2:

When the machine meets a fluctuating load which is over double of the nominal torque, the actual speed of the stirrer shaft will go down quickly to stop.

Display symbol: **Er 4** (see section “**Error codes**”).

Output shaft

The clamping chuck and output shaft permit clamping IKA® recommend stirrer tools (see “**Permitted IKA® Stirrer tools**” section). The output shaft is designed as a hollow shaft, and the opening on the top side of the housing is closed with a stirrer cover. When open the stirrer cover, it is possible for stirring shafts to push out over the top edge of the housing at **standstill**, e.g. during change container.

For safety reasons, the plastic cover must be pushed back into the opening of the housing so that this is properly closed. This is the only way to ensure that working with the unit is safe and that media cannot enter the instrument.



Please see section “Safety instructions”!

Speed display

The rotation speed is adjusted with the rotary knob (B, see **Fig. 1**) on the front of the overhead stirrer.

The rotational speed is displayed directly in revolutions per minute (rpm) on the LED display (C, see **Fig. 1**).

Commissioning

Assemble the overhead stirrer and all necessary accessories on a stable, even, non-slip surface. The **EUROSTAR 200 digital** overhead stirrer must be secured to a stable stand (e.g. **R 2722** or **R 2723**) with a cross-sleeve (e.g. **R 270**). The stirring vessel must always be securely fixed for safety reasons. You must also ensure that the mounting device (stand) is set up in such a way that it is not liable to topple and does not start to move during the stirring procedure.

Accessories must be assembled according to the following assembly instructions (**Fig. 2** to **Fig. 6**).

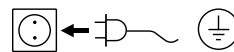

If above conditions are met, the instrument is ready for operation after plugging in the mains plug.

Securing

Securing the extension arm to the overhead stirrer

Diagram (see Fig. 2)

Ensure that the extension is fitted securely. Vibration may cause the screw to become loose. It is therefore necessary for safe use to occasionally check that the extension arm is attached securely. Tighten the hexangular bolt as if required.

Securing the overhead stirrer to the stand

Diagram (see Fig. 3)

First secure the cross sleeve (H) to the stand (I). Then secure the extension arm (J) of the laboratory stirrer in the open side of the cross sleeve which is facing upwards. Once you have set the position required for the stirring procedure, firmly tighten the two clamping bolts (G).

Check that the stirrer is held in position firmly prior to each use and also at regular intervals. The position of the stirrer must only be adjusted when the equipment is stationary and the power supply is disconnected.

Securing the stirring element using the chuck

Diagram (see Fig. 4)

Slide the stirring element (M) into the chuck (L). Tighten the chuck firmly using the chuck key (K). The stirring element must only be changed when the equipment is stationary and the power supply is disconnected.

Securing the stirring shaft protector

Diagram (see Fig. 5)

Use a stirring shaft protector (Q), e.g. **R 301**, to provide protection against injury when working with the instrument.

Use the bolts (U) to attach the plastic half-shell pieces to the stirrer (T), as shown in **Fig. 5**. The screw (S) can be used to adjust the length of the stirring shaft protector.

Check that the stirring shaft protector is held in position securely prior to each use and also at regular intervals. The position of the stirring shaft protector must only be adjusted when the equipment is stationary and the power supply is disconnected.

Securing the mixing vessel to the stand

Diagram (see Fig. 6)

First fix the cross sleeve (H) to the stand (I). Then attach the bracket (Z) of the strap clamp in the open side of the cross sleeve which is facing upwards according to the position of stirrer and the mixing vessel (V), firmly tighten the two clamping bolts (G).

Clamp the mixing vessel (V) with the flexible clamping band (W) and secure the flexible band (W) by means of the clamping lever (X).

Switching on the instrument

Check whether the voltage given on the type plate corresponds to the available mains voltage.

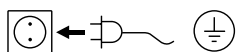

The socket used must be earthed (fitted with earth contact).

If these conditions have been met, the machine is ready to operate when the mains plug is plugged in. If these conditions are not met, safe operation is not guaranteed and the machine could be damaged.

After switch on the main switch (A) as show in **Fig. 1**, the display (C) will display a software version number, and then display the speed setting in last operation after a few second. LED (E) or LED (F) indicate the speed range setting in last operation. Ensure the speed set is suitable for the test medium selected. If in doubt, set the speed adjust knob (B) to the lowest speed (left hand position). Press the knob (B) to start or stop the stirring.

By pressing speed range key (D), the unit could be switch to different modes between high torque and high speed modes.

• Speed setting

Before start the unit, you could preselected required speed with speed adjust knob (B). Then push down knob (B), the unit will speed up to your desired speed. When speed is changed, nominal speed will be displayed on the display (C).

At standstill, speed can be changed between two speed ranges (**I** or **II**) by pressing key (D). In standby mode, the display (C) shows the set speed value.

This stirrer has two different speed ranges:

Range I: low speed/high torque (LED (E))

Range II: high speed/lower torque (LED (F))

• Correct step to change Speed Range:

- Turn off the unit with knob (B)
- Change speed range with key (D)
- Change speed with knob (B)
- Turn on unit with knob (B)
- The speed can be changed at any time during operation
- Speed appears in display (C).

Maintenance and cleaning

The instrument is maintenance-free. It is only subject to the natural wear and tear of components and their statistical failure rate.

Cleaning

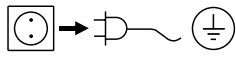

For cleaning disconnect the main plug!

Use only cleaning agents which have been approved by **IKA®** to clean **IKA®** instruments.

Dirt	Cleaning agent
Dye	isopropyl alcohol
Construction material	water containing tenside/ isopropyl alcohol
Cosmetics	water containing tenside/ isopropyl alcohol
Foodstuff	water containing tenside
Fuel	water containing tenside

For materials which are not listed, please request information from **IKA®** application support.

Wear protective gloves during cleaning the instruments.

Electrical instruments may not be placed in the cleansing agent for the purpose of cleaning.

Do not allow moisture to get into the instrument when cleaning.

Before using another than the recommended method for cleaning or decontamination, the user must ascertain with **IKA®** that this method does not destroy the instrument.

Spare parts order

When ordering spare parts, please give:

- machine type
- manufacturing number, see type plate
- item and designation of the spare part see **www.ika.com**, spare parts diagram and spare parts list
- software version.

Repair

Please send in instrument for repair only after it has been cleaned and is free from any materials which may constitute a health hazard.

For repair, please request the “**Decontamination Certificate**” form **IKA®** or use the download printout of it from **IKA®** website: **www.ika.com**.

If you require servicing, return the instrument in its original packaging. Storage packaging is not sufficient. Please also use suitable transport packaging.

Error codes

The fault is shown by an error code in the display (C) as following if the error occurs, e.g. **Er 4**.

Proceed as follows in such cases:

- ☞ Switch the device switch (A) off.
- ☞ Remove the stirrer tool and remove the instrument from the assembly.
- ☞ Reduce the speed and switch on (instrument switch (A)) the device without the stirrer tool.

Error code	Cause	Effect	Solution
Er 2	Motor current sensor fault	motor off	- Switch off the instrument
Er 3	Temperature inside instrument is too high	motor off	- Switch off the instrument and allow it to cool down
Er 4	Motor blockage or overload	motor off	- Switch off the instrument - Decrease the load on the motor and restart again
Er 8	Speed sensor fault or overload	motor off	- Switch off the instrument
Er 21	Safety relay fault	motor off	- Switch off the instrument

If the actions described fails to resolve the fault or another error code is displayed then take one of the following steps:

- Contact the service department
- Send the instrument for repair, including a short description of the fault.

Warranty

In accordance with **IKA®** warranty conditions, the warranty period is 24 months. For claims under the warranty please contact your local dealer. You may also send the machine direct to our factory, enclosing the delivery invoice and giving reasons for the claim. You will be liable for freight costs.

The warranty does not cover worn out parts, nor does it apply to faults resulting from improper use, insufficient care or maintenance not carried out in accordance with the instructions in this operating manual.

Accessories

R 2722	H-stand	RH 5	Strap clamp
R 2723	Telescopic stand	R 301	Stirrer shaft protection
R 270	Cross sleeve	R 301.1	Support holder
R 271	Cross sleeve		

Permitted IKA® stirrer tools

		<i>max. speed (rpm)</i>			<i>max. speed (rpm)</i>
R 1342	Propeller stirrer	≤ 2000	R 1300	Dissolver stirrer	≤ 2000
R 1345	Propeller stirrer	≤ 800	R 1302	Dissolver stirrer	≤ 1000
R 1381	Propeller stirrer	≤ 2000	R 1303	Dissolver stirrer	≤ 2000
R 1382	Propeller stirrer	≤ 2000	R 1352	Centrifugal stirrer	≤ 2000
R 1385	Propeller stirrer	≤ 800	R 1355	Centrifugal stirrer	≤ 800
R 1388	Propeller stirrer	≤ 400	R 1375	Paddle stirrer	≤ 800
R 1389	Propeller stirrer, PTFE	≤ 800	R 1376	Paddle stirrer	≤ 800
R 1311	Turbine stirrer	≤ 2000	R 1330	Anchor stirrer	≤ 1000
R 1312	Turbine stirrer	≤ 2000	R 1331	Anchor stirrer	≤ 1000
R 1313	Turbine stirrer	≤ 800	R 1333	Anchor stirrer	≤ 800

Technical data

Speed range I (high torque) Speed range II (high speed)	rpm	0/6-400 0/30-2000
Speed setting		Stepless
Speed display		7-Segment LEDs
Speed setting accuracy	rpm	±1
Speed measurement deviation		Speed < 300 rpm: ±3 rpm Speed > 300 rpm: ±1%
Max. torque at stirrer shaft	Ncm	Range I : 200 Range II : 40
Max. stirring quantity (water)	ltr	100
Max. viscosity	mPas	100000
Permitted on time	%	100
Nominal voltage	VAC	230±10% (EURO) 115±10% (USA)
Frequence	Hz	50/60
Max. input power	W	130
Max. output power at stirring shaft	W	84
Protection type acc. to DIN EN 60529		IP 40
Protection class		I
Excess voltage category		II
Contamination level		2
Protection at overload		Yes/motor current limitation
Fuse (on mains plate)	A	T 4 A (IKA® Ident. No. 2585100)
Ambient temperature	°C	+5 to +40
Ambient humidity (rel.)	%	80
Drive		Brushless motor
Clamping chuck – clamping range	mm	0,5-10
Hollow shaft internal diameter	mm	10,3
Extension arm (ØxL)	mm	16x220
Housing		Coated aluminium casting and thermoplastic plastic
Dimensions (WxDxH) (without extension arm)	mm	91x209x274
Weight (with extension arm and clamping chuck)	kg	4,6
Operation at a terrestrial altitude	m	max. 2000

Subject to technical changes!

IKA

designed for scientists

IKA-Werke GmbH & Co. KG

Janke & Kunkel-Straße 10, 79219 Staufen, Germany

Phone: +49 7633 831-0, Fax: +49 7633 831-98

eMail: sales@ika.de

USA

IKA Works, Inc.

Phone: +1 910 452-7059

eMail: sales@ika.net

KOREA

IKA Korea Ltd.

Phone: +82 2 2136 6800

eMail: sales-lab@ika.kr

BRAZIL

IKA Brazil

Phone: +55 19 3772 9600

eMail: sales@ika.net.br

MALAYSIA

IKA Works (Asia) Sdn Bhd

Phone: +60 3 6099-5666

eMail: sales.lab@ika.my

CHINA

IKA Works Guangzhou

Phone: +86 20 8222 6771

eMail: info@ika.cn

POLAND

IKA Poland Sp. z o.o.

Phone: +48 22 201 99 79

eMail: sales.poland@ika.com

JAPAN

IKA Japan K.K.

Phone: +81 6 6730 6781

eMail: info_japan@ika.ne.jp

INDIA

IKA India Private Limited

Phone: +91 80 26253 900

eMail: info@ika.in

UNITED KINGDOM

IKA England LTD.

Phone: +44 1865 986 162

eMail: sales.england@ika.com

VIETNAM

IKA Vietnam Company Limited

Phone: +84 28 38202142

eMail: sales.lab-vietnam@ika.com

Thailand

IKA Works (Thailand) Co. Ltd.

Phone: +66 86 375 7451

eMail: sales.lab-thailand@ika.com

Turkey

IKA Turkey A.Ş.

Phone: +90 216 394 43 43

eMail: sales.turkey@ika.com

Discover and order the fascinating products of IKA online:
www.ika.com



IKAworldwide



IKAworldwide /// #lookattheblue



@IKAworldwide